

Model 257S Relief Valve

Installation and Maintenance Instructions

Purpose

Safe practice in the transmission, distribution and utilization of gas requires a device to limit line pressure to a predetermined safe maximum, preventing overpressuring the system. Mechanical failure, accidents or foreign matter in the lines may render other types of safeguards inoperative and cause a dangerous overpressuring of the system.

Leaking bypass valves occasionally will permit pressure to build during off-peak hours. Pressure regulators with damaged valves or seats are not able to effect a shutoff when required, thereby permitting a possibly dangerous overpressure condition.

The surest safeguard is a device that will open as necessary and discharge to atmosphere enough of the excess to maintain a safe pressure in the system.

The most beneficial and commonly used device is a mechanical relief valve, correctly installed at a safe dispersal point and set to discharge to atmosphere when line pressure exceeds a predetermined set-point.

Compact and easy to install, the relief valve offers an economical installation with large relieving capacity. It automatically closes when the pressure returns to normal. Many times, a small relief valve can be used advantageously with a larger relief valve. The smaller relief valve can be set for a lower discharge pressure to take care of minor pressure fluctuations without the necessity of venting a large amount of gas to atmosphere through the larger relief valve.

Operation

The operation of Sensus Safety Relief Valves is beneficial and simple. They are normally installed in a vertical line with the outlet usually connected to a rigid discharge stack with a suitable protective cap. A soft-seated valve is exposed to line pressure and, under normal conditions, is held tightly closed by the force exerted by the spring. When line pressure increases sufficiently to overcome the closing force, the relief valve opens to discharge gas. The relief valve automatically closes after pressure returns to normal.

Installation and Start-Up

1. Thoroughly purge inlet piping to remove dirt and debris that could damage the relief valve or impair its operation. Make certain that the inside of the relief valve and piping are free of dirt, foreign matter and other debris.
2. Install the relief valve. Make certain flow through the relief valve is in the correct direction. High pressure connects to the inlet side. Be sure that shipping screens or covers, if used, are removed.

On flanges, tighten bolts evenly. On screwed connections, apply pipe dope to male threads only.



CAUTION

It is the user's responsibility to assure that all regulator vents and/or vent lines exhaust to a non-hazardous location away from ANY POTENTIAL sources of ignition. Where vent lines are used, it is the user's responsibility to assure that each regulator is individually vented and that common vent lines ARE NOT used.

3. The vent connection is an escape path for flammable gas and it must be located and/or piped so that potential discharge occurs in a safe area away from buildings, open flames, collection areas, arcing devices, etc.

Relief valves that are installed indoors or in a non-vented area must be vented to the outside. Simply run vent piping from the vent and relief valve discharge connections to a non-hazardous location on the outside away from any potential sources of ignition. The vent piping must be connection size or larger and piped to a safe area.

The outlet of the vent piping must allow for the free and unobstructed passage of air and gas and must be protected against the potentials listed in these instructions.

4. For outdoor installations, it is recommended that the relief valve be installed so the potential for water or other foreign matter entering the relief valve and interfering with the proper operation is avoided.
5. Check all connections for leaks.



CAUTION

Turn gas on very slowly. If an outlet stop valve is used, it should be opened first. Do not overload diaphragm with a sudden surge of inlet pressure. Monitor the overload outlet pressure during start-up to prevent an outlet pressure overload.

6. Put the relief valve into operation by very slowly opening the upstream block valve **A**. (See illustration on page 5.)
7. Set adjusting screw **10** for the required relief pressure. Turn it clockwise to increase the pressure and counter-clockwise to decrease it. Only make this adjustment when gas is actually flowing through the relief valve. After adjustment is complete, locknut **11** should be tightened firmly and seal cap **1** replaced.
8. To shut down, carefully close valve **A**.



CAUTION

Keep pipe dope and all other foreign substances out of the relief valve.

The vent must be positioned to protect against flooding, drain water, ice formation, traffic, tampering, etc. The vent must be protected against nest building animals, bees, insects, etc. to prevent vent blockage and minimize the chances for foreign material to collect in the vent side of the diaphragm.

Servicing and Adjustment

General Notes

1. Make sure both the inlet and outlet chambers of the relief valve are entirely depressured before servicing.
2. Carefully note the location and position of disassembled parts to be certain reassembly is correct. Inspect each one carefully and replace those that are worn or damaged or otherwise unsatisfactory.
3. Use lubricants sparingly and with care to avoid exposing tacky surfaces to the gas stream. Such surfaces could cause dirt accumulation on close clearance parts.

Use moly or silicone type lubricants. Avoid the use of petroleum based types.

An application of silicone based lubricant to the other O-rings and the tetraseals in the relief valve will also help assure their tightness.



CAUTION

Relief valves are overpressure control devices with numerous moving parts subject to wear and are dependent upon particular operating conditions. To assure continuous satisfactory operation, a periodic inspection schedule must be adhered to with the frequency of inspection determined by the severity of service and applicable laws and regulations.

To Change Spring

1. To change spring **14**, close valve **A**, remove cap **1**, release nuts **11**, turn adjustment screw **10** counterclockwise, remove cap screws **4**, cover cap **5**, spring ferrule **12** and ball bearing **13**.
2. Remove spring **14**. To install new spring, reverse the procedure noted above.
3. Open valve **A**. Check relief valve for set point, leakage and reseat. Modify badge information.

To Service Diaphragm

1. To service diaphragm **20** and/or valve **41**, complete step 1 of "To Change Spring", remove spring **14**, cap screws **26**, nuts **27** and upper case **8**.
2. Remove valve, diaphragm and stop plate and stem assembly from body. To change diaphragm, remove nut **16**, upper diaphragm pan **19** and diaphragm and gasket assembly **20**. Install new diaphragm and gasket and reverse procedure.

To Service Valve

1. To service valve, remove roll pin **40**. Remove and install new valve **41**. Reverse procedure.



CAUTION

The seating surface of valve **41** should not be damaged during assembly. Stem **43** should be carefully placed into bushing **37** prior to carefully pushing the valve, diaphragm, stop plate and stem assembly into place.

To Service Guide Bushing

1. To service guide bushing **45**, complete the steps in "To Service Diaphragm" above, remove set screws **48** and pull guide bushing assembly out of body. Reverse to install.

To Service Valve Disc

1. To service valve disc **44**, complete "To Service Guide Bushing" above, remove bottom cap **35** and retaining screws **44c**, and remove valve disc assembly **44** through the body. Reverse procedure to install.

Temperature Limits

The Model 257S Relief Valve can be used for flowing temperatures from -20°F to 150°F.

Buried Service

The 257S Relief Valve is **not** recommended for buried service.

Model 257S Relief Valves 2", 3", 4" Parts List

Illustration Number	Description	Part Number
1	Seal Cap	090-00-005-02
1a	Tetraseal (or O-ring) 1 1/4" x 2"	904092
4	Hex. Cap Screw 5/16" – 18 x 1" Gr. 5, 8 used	910030
5	Housing Cover, ductile	091-16-380-00
6	Housing Cover, Gasket	091-00-066-30
7	Vent Cap, 1/4" NPT	137-02-505-03
8	Upper Diaphragm Case	091-00-003-00
10	Spring Adjusting Screw	090-16-007-02
11	Hex. Steel Jam Nut, 5/8" – 11, 2 used	921407
12	Top Spring Button	091-00-009-00
13	Thrust Bearing, 3/8" dia. Stainless Steel Ball	930510
14	Spring, Yellow 2 to 4 psi	091-00-021-05
	Spring, Gray 4 to 8 psi	091-00-021-04
	Spring, Blue 8 to 12 psi	091-00-021-03
	Spring, Red 12 to 24 psi	091-00-021-02
	Spring, Brown 24 to 48 psi	091-00-021-01
	Spring, Black 48 to 65 psi	091-00-021-00
	Spring, Black with White Inner Spring 65 to 100 psi	091-00-021-08
15	1/4" NPT Sq. Hd. Steel Pipe Plug, 4 used	906055
16	Elastic Stop Nut, 3/4" – 16	903958
19	Diaphragm Plate, Upper	091-00-010-01
20*	Diaphragm and Gasket Assembly, 5" Roll-Out	115-16-350-60
21	Piston	115-16-022-70
22	O-ring, 4 7/8" x 5 3/8"	934055
23	23a Stainless Steel Ball, 1/4" dia.	930506
	23b Truss Hd. (#8 – 32 x 3/8")	950426
24	Diaphragm Stud	115-16-058-60
25	Roll Pin, 3/16" x 1 1/8" lg.	901699
26	Hex. Steel Bolt, 3/8" – 16 x 2 lg., Gr. 5, 8 used	910059
27	Hex. Steel Nut, 3/8" – 16, 8 used	920853
28	Tetraseal 6 1/4" x 6 1/2"	904080
29	Piston Stop Ring	115-16-037-60
35	Bottom Inspection Plate	115-16-004-60
36	Tetraseal 5 1/4" x 5 1/2"	904205
37	Bushing, Stainless Steel	115-16-085-52
40	Roll Pin, 3/16" x 7/8" lg.	904229
90	Nameplate	090-00-086-03
91	Nameplate	115-16-086-60
92	Rd. Hd. Type U Drive Screw, #4 x 3/16" lg., 4 used	903004

*Always install with cloth side and gasket toward spring.

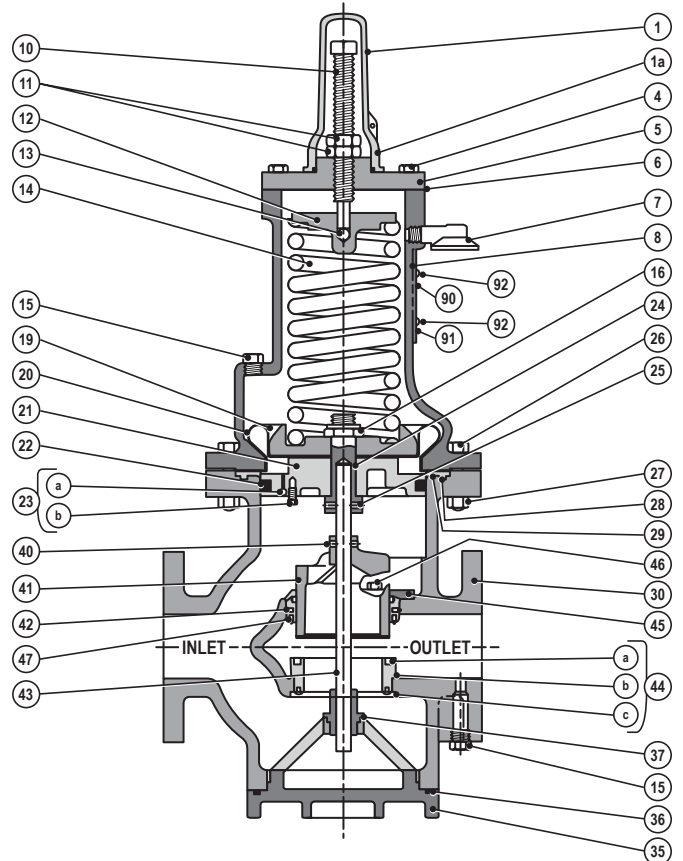

GIM1450A-005

2" and 3" Model 257S Relief Valve

How To Order

When ordering parts, please specify the following:

1. **Part number, description and quantity** required of each part.
2. **Pipe size and model number** of the relief valve.
3. If available, the **serial number** of the relief valve should also be included.

Model 257S Relief Valves 2", 3", 4" Parts List

2" Model 257S

Illustration Number	Description	Part Number
30	2" Body, Flanged ANSI 125 lb., FF	115-16-001-62

3" Model 257S

Illustration Number	Description	Part Number
30	3" Body, Flanged ANSI 125 lb., FF	115-20-001-62

2" and 3" Model 257S

Illustration Number	Description	Part Number
41	Valve	115-16-011-62
42	O-ring, 2 ⁷ / ₁₆ " x 3 ¹ / ₄ "	934039
43	Valve Stem	115-16-016-60
44	44a Valve Disc (Molded) 44b O-ring, 2 ¹³ / ₁₆ " x 3" 44c Ref. Sc. (#8 - 32 x 3 ³ / ₁₆ ")	115-16-315-00 950647 950648
44	For replaceable orifice and valve design, 2" after SN D49877 and 3" after SN D49759 44a Valve and Disc Assembly 44b O-ring, 1 ¹³ / ₁₆ " x 3" 44c Ret. Screw #8 - 32 x 3 ³ / ₁₆ "	115-16-315-00 950647 950648
44	For non-replaceable orifice design, 2" before SN D49878 and 3" before SN49760 44a Valve Disc, Polyurethane Orange	115-16-017-65
45	Valve Guide Assembly	115-16-373-00
46	Mounting Bolt, 4 Used	950463
47	O-ring, 3 ¹ / ₄ " x 3 ¹ / ₂ "	934314

4" Model 257S

Illustration Number	Description	Part Number
30	4" Body, Flanged ANSI 125 lb., FF	115-16-011-62
41	Valve	115-22-011-61
42	O-ring, 3 ⁷ / ₁₆ " x 4 ¹ / ₄ "	934047
43	Valve Stem	115-22-016-62
44	For replaceable orifice and valve design, 4" after SN D 50065 44a Valve Disc (Molded) 44b O-ring 4" x 4 ³ / ₁₆ " 44c Ret. Sc. (#8 - 32 x 3 ³ / ₁₆ ")	115-16-315-00 902779 950648
44	For non-replaceable orifice design, 4" before SN 50066 44a Valve Disc Polyurethane Orange 45 Valve Guide Assembly 47 O-ring, 4 ¹ / ₂ " x 4 ¹ / ₁₆ " 48 Retaining Screw, 4 Used	115-22-017-65 115-22-373-00 906832 950662

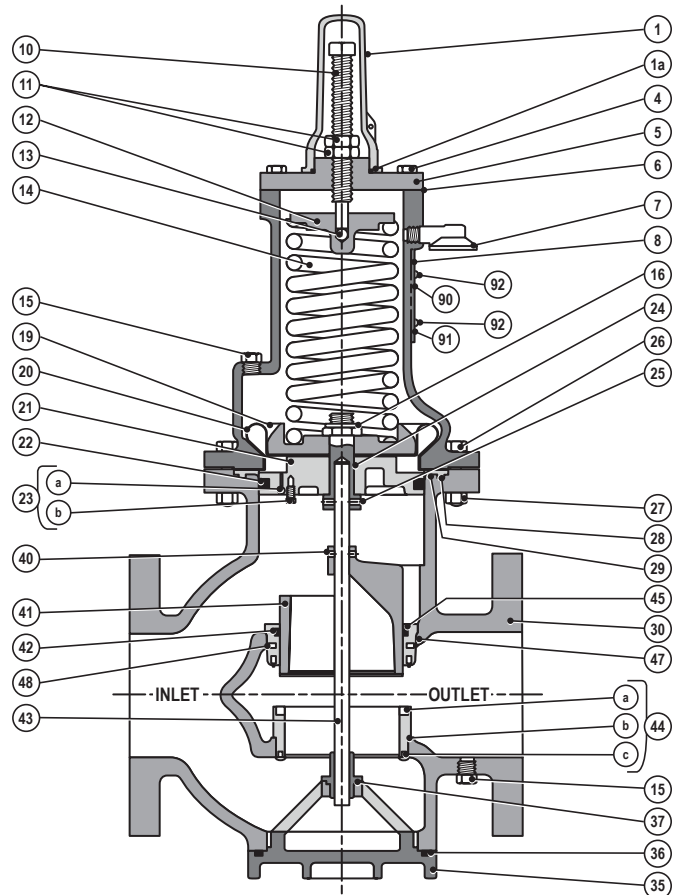

GIM1450A-010

4" Model 257S Relief Valve

Other Gases

The Model 257S Relief Valve is mainly used on natural gas services; however, this relief valve will perform equally well on other gases. When using the Model 257S Relief Valve on other gases, the relief valve capacities must be adjusted using the following correction factors:

Other Gases	Correction Factor
Air (Specific Gravity 1.0)	0.77
Propane (Specific Gravity 1.53)	0.63
1350 BTU Propane-Air Mix (1.20)	0.71
Nitrogen (Specific Gravity 0.97)	0.79
Dry Carbon Dioxide (Specific Gravity 1.52)	0.63

For other non-corrosive gases,
Correction Factor = $\sqrt{\frac{0.60}{\text{Specific gravity of the gas}}}$

For use with gases not listed above, please contact your Sensus Representative or Industrial Distributor for recommendations.

Typical Arrangement and Dimensions (Indoor or Outdoor Installation)

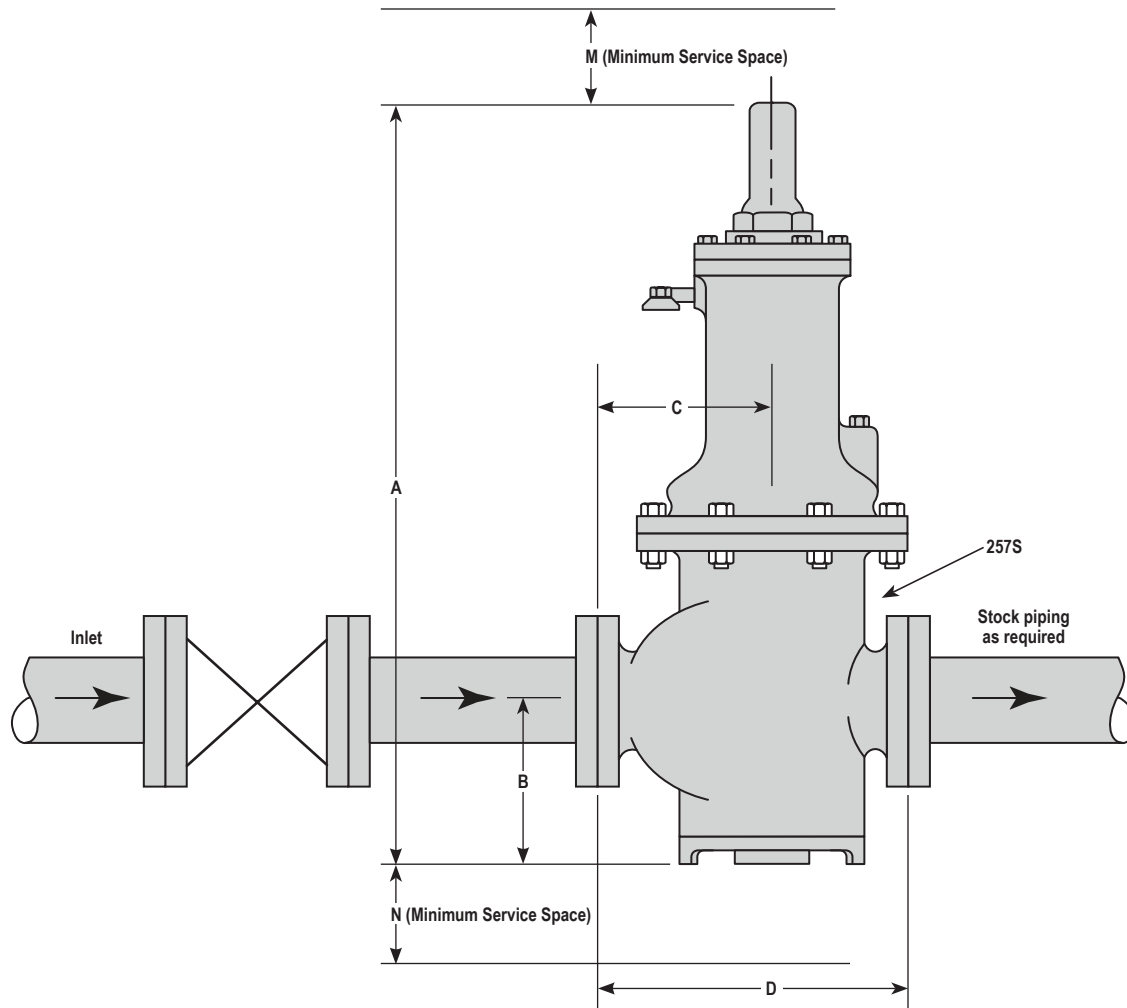

GIM1450A-015

Dimensions

Size	A	B	C	D	M	N
2"	24¼"	5¾"	5¾"	10"	5"	5"
3"	24¾"	5¾"	6½"	11¼"	5"	5"
4"	26½"	5¾"	6¾"	12½"	5"	5"

Weight (lbs)

2"	3"	4"
95	105	125

Relief Pressure Adjustment Range

Relief Pressure Range	Color of Spring	Part Number
2 to 4 psi	Yellow	091-00-021-05
4 to 8 psi	Gray	091-00-021-04
8 to 12 psi	Blue	091-00-021-03
12 to 24 psi	Red	091-00-021-02
24 to 48 psi	Brown	091-00-021-01
48 to 65 psi	Black	091-00-021-00
65 to 100 psi	Black with a White Inner Spring	091-00-021-00 091-00-021-08

NOTE: Do not exceed maximum pressure of each spring.

Model 257S Relief Valve

Installation and Maintenance Instructions



Authorized Distributor:

All products purchased and services performed are subject to Sensus' terms of sale, available at either <http://na.sensus.com/TC/TermsConditions.pdf> or 1-800-METER-IT. Sensus reserves the right to modify these terms and conditions in its own discretion without notice to the customer.

This document is for informational purposes only, and SENSUS MAKES NO EXPRESS WARRANTIES IN THIS DOCUMENT. FURTHERMORE, THERE ARE NO IMPLIED WARRANTIES, INCLUDING WITHOUT LIMITATION, WARRANTIES AS TO FITNESS FOR A PARTICULAR PURPOSE AND MERCHANTABILITY. ANY USE OF THE PRODUCTS THAT IS NOT SPECIFICALLY PERMITTED HEREIN IS PROHIBITED. © 2012 Sensus.