



Auto-Adjust[®] Turbo-Meter

The Most Advanced Turbine Meter Technology Ever Produced.
Meets All Applicable ISO & OIML Standards.

Auto-Adjust[®]
G250-G4000
Top-entry,
Dual-rotor
Turbo-Meters



Auto-Adjust® Turbo-Meters

Auto-Adjust Principle	3
Features/Benefits	4-5
Self-Checking, Self-Adjusting Capabilities	6
Accuracy Savings Chart	7
Savings Scenarios	8-9
Electronic Measurement System Options	10
Module Upgrades and Exchanges	11
Typical Performance Data Tables	12-19
Dimension Tables	20-21
AAT Training Information	22
High Pressure Calibration Facilities	23
About Equimeter	23-24

Table of Contents

Accuracy Savings and Maintenance Savings = Auto-Adjust Principle

Designed to combat the inherent weaknesses of other meter technologies and protect the user from under- and over-billing customers, the Auto-Adjust (AAT) Turbo-Meter is the world's only meter that features continuous accuracy monitoring, continuous accuracy adjustment, and Continuous Measurement Certainty™. The Auto-Adjust Turbo-Meter's dual rotor design and patented algorithms are the centerpiece of a meter technology that:

- Is virtually insensitive to deviations in upstream conditions, component wear and contaminants.
- Alerts users to unstable upstream conditions and unacceptable installations.
- Allows for remote monitoring of adjusted and corrected volume.
- Reduces the number of maintenance and testing site visits.

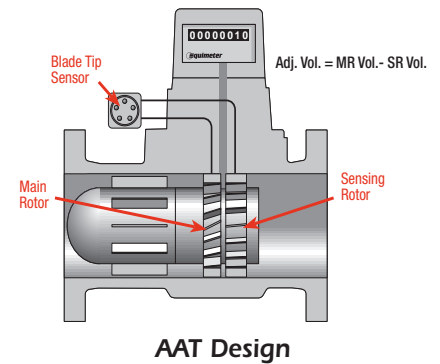

Accuracy Savings

The Auto-Adjust's unique dual rotor design (sensing rotor downstream of main rotor) offers superior accuracy over all other turbine meter technologies and provides the user significant dollar savings in the process. The Auto-Adjust detects and self-adjusts for changes in upstream flow conditions such as jetting, pulsations, and swirl, and detects and self-adjusts for meter component wear and contamination. Such conditions are common in gas line operations and cause other meters to provide inaccurate flow measurement. With the AAT, you can avoid over- and under-billing situations and costly disputes, because the AAT provides an adjusted volume output and Continuous Measurement Certainty™. See the AAT Cost Justification section of this publication or our interactive AAT Calculator at www.equimeter.com to quantify the AAT's potential accuracy savings.



Telus Software

Maintenance Savings

The AAT's unique self-checking feature provides constant remote accuracy monitoring capabilities and in-line field diagnostics that save the user significant maintenance and performance-monitoring dollars. The AAT's self-checking output can be remotely monitored on the user's PC via a modem, eliminating the need for site visitation unless an accuracy deviation is detected. The AAT's performance can also be tested in-line using the Equimeter Field Prover, eliminating the need for meter removal and gas flow interruption. Both monitoring options eliminate spin testing requirements, reduce the number of required site visits, and drastically reduce the dollars spent on maintenance.



Field Prover

Auto-Adjust Turbo-Meters, Design Features

1 Any of a wide variety of mechanical, electromechanical, or electronic readout devices can be directly mounted to the meter index plate.

2 Calibration of meter output shaft rotations to precise engineering units is effected by change gears which are readily accessible at the top of the intermediate gear assembly.

3 A magnetic coupling transmits rotor rotations from the pressurized to the non-pressurized area.

4 All moving parts are contained in an interchangeable module which lifts out of the meter body. Once installed, the body remains in the line.

5 Improved rotor design extracts maximum kinetic energy from the flowing gas. Dynamic balancing of rotor and hub assembly assures minimum drag at all flow rates.



6 Optimized nose cone with integral straightening vanes minimizes the need for long inlet piping runs.



7 Physically independent sensing rotor measures changes in gas exit angle coming off the main rotor. Exit angle changes are caused by drag, jetting, swirl, pulsations, and contamination and allow the “self-checking” and “self-adjusting” calculations to be performed.

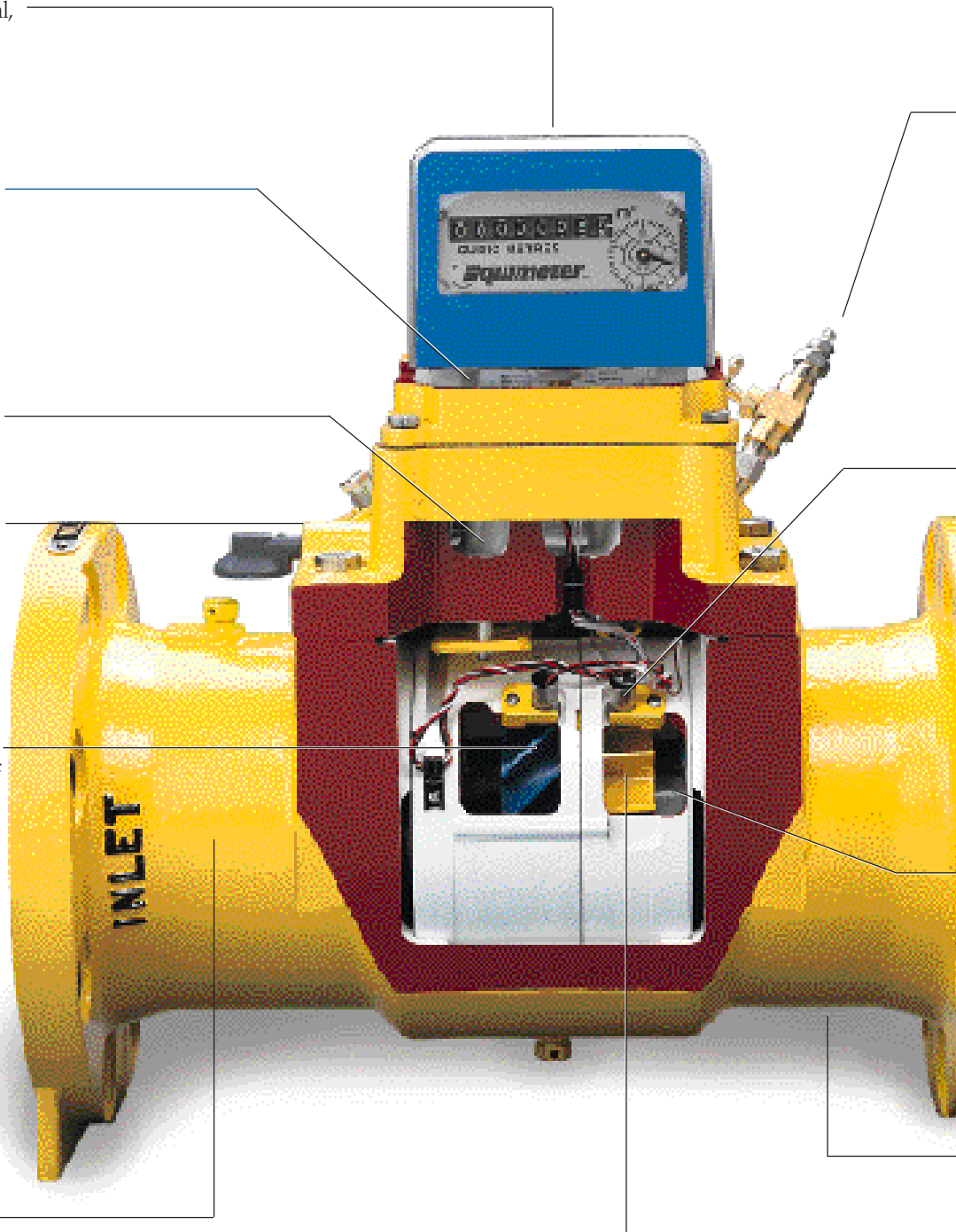

What's New with the Auto-Adjust Turbo-Meter?

Equimeter is committed to technological growth through continual development of our measurement products and service programs. While the Auto-Adjust Turbo-Meter has been the most accurate and technologically advanced turbine meter on the market for many years, we just made it better with a series of improvements.

- 8 An external fitting permits rotor shaft bearing lubrication and flushing while the meter is operating. Automatic oiler also available.



- 9 Blade tip sensors provide high frequency pulse outputs for electronic measuring systems.



- 10 Advanced meter design achieves thrust load balancing for rotor shaft bearings at all operating conditions.

- 11 Gears and other moving parts are housed in a sealed chamber protected from line contaminants. Pressure equalization is achieved via screened orifices located on the upstream and downstream sides of the chamber.

- 12 3-Pipe Diameter Body

30-Degree Rotor Blade Angle! In addition to the standard 45-degree rotor, the AAT now offers a 30-degree rotor that provides up to 64% more flow capacity through the meter. This will increase the capacity of your system without costly changeout of the meter body or piping. This option allows the user the flexibility of upgrading current 45-degree models to 30-degree versions with a simple module changeout. Meter maintenance, body size, and installation methods do not change, regardless of the chosen blade angle.

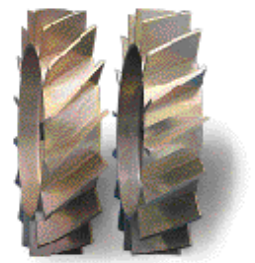

Blade Tip Sensors! Blade tip technology provides 2-4 times higher pulse resolution than a slot sensor along with a redundant output. Its sturdy design is not sensitive to pressure changes or contaminants, and field maintenance is easier since the module doesn't need to be disassembled for blade tip sensor repair.



Automatic Oiler! Users can now avoid regular maintenance trips to their meter sites by using the meter-mounted Automatic Oiler.

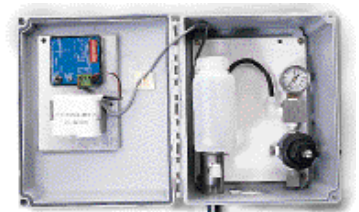

Self-Checking and Self-Adjustment = Continuous Measurement Certainty™!

The AAT's Exclusive Self-Checking Capability:

The AAT generates a self-checking output that is derived from the ratio between the main and sensing rotor pulses. This output is referred to as Delta A (ΔA). The self-checking feature indicates how much adjustment the meter is making, thereby warning the user of meter or flow-conditioning problems *and allowing him to quantify the resulting accuracy savings.*

Self-Checking Equation

$$\left(\frac{\frac{\text{Field}}{100} V_m}{V_s} - 1 \right) - \bar{A} = \Delta A$$

- $V_m = P_m/K_m$
 - $P_m =$ Pulses from Main Rotor
 - $K_m =$ MR Factor (pulse/ft³)
- $V_s = P_s/K_s$
 - $P_s =$ Pulses from Sensing Rotor
 - $K_s =$ SR Factor (pulse/ft³)
- $\bar{A} =$ Average amount of adjustment from factory calibration
- $\Delta A =$ Average change in mechanical output accuracy from original calibration

The AAT's Exclusive Self-Adjusting Capability:

The AAT's main and sensing rotors are equipped with high-resolution pulse generators that send pulses to an instrument equipped with the AAT algorithms for calculation. The pulse output from the main rotor is calibrated to record a volume of 110% of true flow passing through the meter. The pulse output from the sensing rotor is calibrated for 10% of true flow passing through the meter. Because of the exit angle relationship between the two rotors, the gas totaled by the meter – the “adjusted volume”- is calculated by taking the main rotor's 110% of volume and subtracting the sensing rotor's 10% of volume for accurate, adjusted measurement of 100% gas volume flow.

Suppose that an increase in mechanical friction causes the main rotor to slow 2%. The result is that the main rotor measures 108% of true volume while the sensing rotor detects the change in main rotor speed and also slows down 2%. The sensing rotor thus measures 8% of flow volume.

Self-Adjusting Equation

$$\text{M.R. Volume} - \text{S.R. Volume} = \text{Adjusted Volume}$$

$$108\% - 8\% = 100\%$$

While a standard meter will be under-registering by 2%, resulting in lost revenues, the self-adjusted output of the AAT will be accurate.

Savings

The Auto-Adjust System's Accuracy Savings

The patented self-adjusting and self-checking features enable the user to avoid billing disputes and under-billing scenarios and thereby reduce operating costs and increase revenues.

The chart below illustrates the accuracy savings achieved at given conditions by using the Auto-Adjust System rather than other meter technologies (*savings will vary due to loads, accuracy, pressure, and gas costs*).

METER SIZE	ROTOR DEGREE ANGLE	AAT MODEL	PRESSURE bar/psi	MAX FLOW RATE %	DAYS OPERATED PER YEAR	HOURS OPERATED PER DAY	METER* ERROR %	\$ COST OF GAS PER SCF	CALCULATED** ANNUAL SAVINGS
G250/DN100 (4")	45	AAT-18	27.6/400	75	365	24	0.2	0.004	\$28,435
G400/DN100 (4")	30	AAT-27	27.6/400	75	365	24	0.2	0.004	\$42,626
G650/DN150 (6")	45	AAT-35	27.6/400	75	365	24	0.2	0.004	\$55,293
G1000/DN150 (6")	30	AAT-57	27.6/400	75	365	24	0.2	0.004	\$90,035
G1000/DN200 (8")	45	AAT-60	27.6/400	75	365	24	0.2	0.004	\$94,766
G1600/DN200 (8")	30	AAT-90	27.6/400	75	365	24	0.2	0.004	\$142,175
G2500/DN300 (12")	45	AAT-140	27.6/400	75	365	24	0.2	0.004	\$221,119
G4000/DN300 (12")	30	AAT-230	27.6/400	75	365	24	0.2	0.004	\$363,295

* This represents an example of the amount of gas unmeasured in another meter but for which the AAT adjusts using its dual rotor technology and patented algorithms.

Using the following formula, you can calculate what your accuracy savings would be under conditions unique to your metering system:

Your average flow rate scfh (see capacity tables) x meter inaccuracy (%) = AAT Recovered Flowrate**.

AAT Recovered Flow Rate x days/yr. x hours/day x # of meters x cost of gas = **YOUR SAVINGS**.

To easily experiment with different conditions and savings scenarios, please access the interactive AAT Cost Savings Calculator at www.equimeter.com.

** By adjusting for error attributable to mechanical and flow profile abnormalities, the AAT allows you to recover (and bill for) gas that would otherwise be lost. Savings calculated in U.S. dollars.

The Auto-Adjust Turbo-Meter: Your Solution to Poor Flow Profile, Meter Wear, and Line Contaminants

The following scenarios illustrate conditions that would degrade the accuracy of other meters and cause lost revenues, unaccounted-for gas, and billing disputes.

Retarding Torque due to Drag or Mechanical Wear

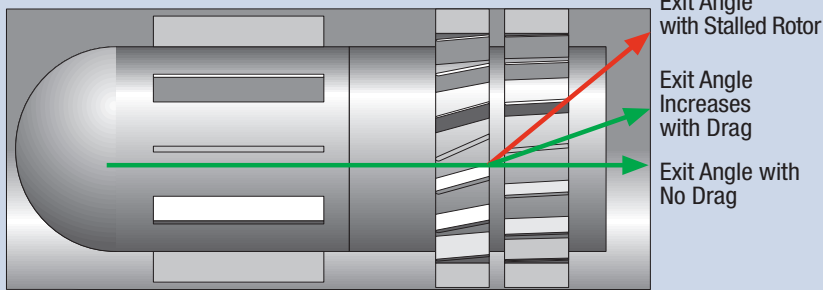

Worn bearings or mechanical drag can reduce main rotor speed. This slow-down reduces the speed of the sensing rotor and allows for detection of the condition. The Auto-Adjust is the only meter technology that provides detection and adjustment for drag and retarding torque.

Jetting (non-uniform flow)

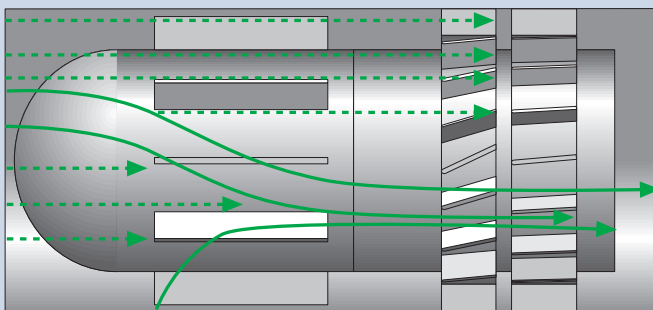

Upstream piping, filters, strainers, regulators, and misaligned gaskets can cause jetting, which creates a stream of high-velocity concentrated gas and a faster moving main rotor. The increased velocity speeds up the sensing rotor, allowing for the detection of the condition. The Auto-Adjust is the only meter technology that provides detection and adjustment for jetting.

Positive (shown) and Negative Swirl

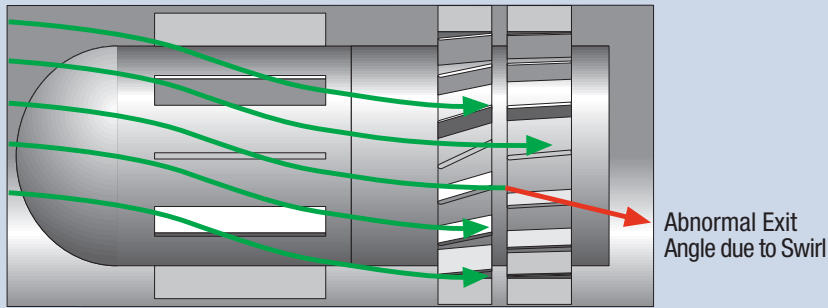

Swirl will cause the main rotor to speed up (positive swirl) or slow down (negative swirl) as flow strikes the main rotor at an abnormal angle. The sensing rotor detects the abnormal exit angle from the main rotor and slows (negative swirl) or speeds up (positive swirl) proportionally to the main rotor. The Auto-Adjust is the only meter technology that provides detection and adjustment for swirl.

Pulsation

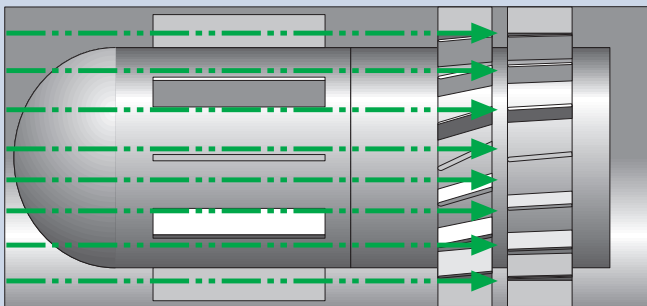

Pulsating flow causes a cyclical slowing and speeding of the main rotor. This fluctuation in speed affects the sensing rotor as well and allows for detection of the condition. The Auto-Adjust is the only meter technology that provides detection and adjustment for pulsating flow.

Change in Flow Area due to Contaminants

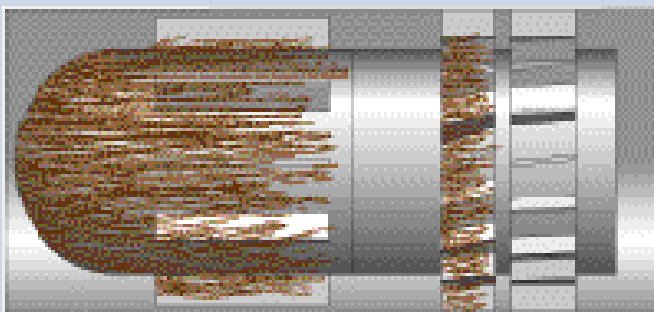

Rotor and nose cone contaminant buildup decreases flow area and results in higher velocity gas and main rotor speed-up. The increased velocity causes the sensing rotor, in turn, to speed up, thus detecting and adjusting for the condition. The Auto-Adjust is the only meter technology that provides detection and adjustment for meter contamination.

Auto-Adjust Electronic Measurement System Options

Standard Electronic Readout –

With the Standard Electronic Readout (SER), the Auto-Adjust Turbo-Meter can perform its self-checking and self-adjustment capabilities. The SER tells the user how the meter is performing and provides the adjusted volume reading at line conditions.

The SER performs its functions using rotor speed signals from the meter. The ratio of the speeds of the main and sensing rotors is calculated and compared to original calibration. If the ratio has changed, the amount is determined and the relative percentage of the deviation is displayed through the “normal” or “abnormal” indicator lights mounted on the SER’s front panel.

AutoCorrector –

The AutoCorrector is a meter-mounted volume corrector designed exclusively for the Auto-Adjust Turbo-Meter. The AutoCorrector computes the adjusted line volume and ΔA self-checking value using the AAT Algorithms. It then calculates the true, corrected volume throughput of the Auto-Adjust Turbo-Meter using measured gas pressure, measured gas temperature, and the AGA NX-19 compressibility ratio. The AutoCorrector has the additional capability of indicating the presence of non-steady flow or severe pulsating flow with a non-steady flow LED indicator.

Serial communications with the AutoCorrector allow continuous monitoring of the AAT’s performance. Together, the AutoCorrector and AAT provide unprecedented gas measurement solutions, including features such as programmable load survey data storage for up to one year, remote communications, password protection, multiple serial ports, corrected and adjusted line volume outputs, alarm outputs and a dual compartment enclosure with hinged doors.

AAT Field Prover –

Using the portable, battery-operated Auto-Adjust Turbo-Meter Field Prover, a single field technician can accomplish the field proving process in a matter of minutes. No gas is bypassed or blown to the atmosphere, and the AAT is not removed from service during the proving process.

The Field Prover will display a direct digital readout to two decimal places for any deviation of the meter’s error from the original factory calibration. The AAT Field Prover is intrinsically safe and a portable tool for quickly and accurately proving the mechanical, electronic, and adjusted output of the Auto-Adjust.

AAT Algorithm Partners –

Selected companies have been authorized to embed firmware containing the proprietary AAT Algorithms in their instruments. This provides added flexibility in designing and equipping your Auto-Adjust measurement system.

Contact your Equimeter sales representative for information on current AAT Algorithm partners.

End users may also license the AAT Algorithms from Equimeter for restricted use at a specified site or with a specified instrument.

Note: To take complete advantage of all Auto-Adjust capabilities, use the AAT with an AutoCorrector instrument and monitor it via a 2400 Modem with TELUS Software as illustrated below:

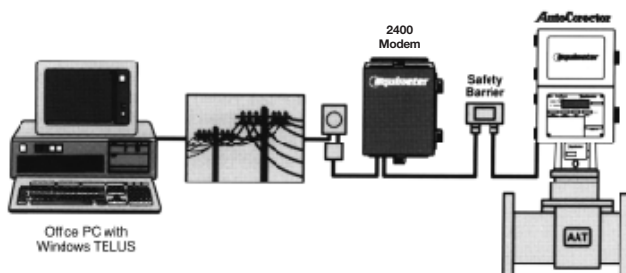

SER



AutoCorrector



Field Prover

Auto-Adjust Upgrades & Exchanges

To help you cost-effectively take advantage of AAT technology and all the advances available, Equimeter offers a complete line of replacement meter modules and upgrades to conveniently enhance your current Equimeter turbines. Here's an overview:

Product Enhancement	Advantage	New Meter Module Required	Upgraded Meter Without Body Removal
Slot Sensor to Blade Tip Sensor	<ul style="list-style-type: none"> • Improved reliability • Reduced maintenance • Easier access to components • Redundant outputs • High pulse resolution 	NO	YES
45° Rotor to 30° Rotor	<ul style="list-style-type: none"> • Up to 64% more capacity • Same body 	NO	YES
Mark II to AAT	<ul style="list-style-type: none"> • Continuous Measurement Certainty™ 	YES	YES

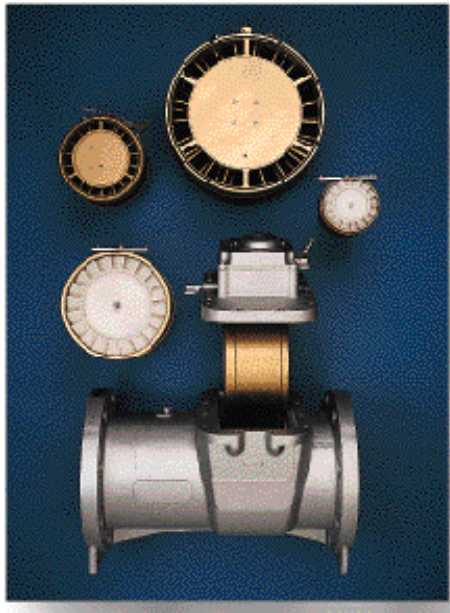

When exchanging modules, all AAT meters can be upgraded without removing the meter body from the line so you avoid lengthy service interruptions. Equimeter maintains a stock of new and factory rebuilt, calibrated measurement modules for all AATs. Each module is shipped with a 5-point calibration curve, plus the appropriate set of change gears. Illustrated instructions for module changeout are also supplied.

DN100 (G250) A100U45 AUTO-ADJUST 45° ROTOR ANGLE (S.I. Units - cubic meters)

COMPRESSIBILITY RATIO	METER PRESSURE	MAXIMUM FLOWRATE	MAXIMUM FLOWRATE	Mechanical Output				Auto-Adjust Output				APPROX. PRESS LOSS @510 Nm ³ /hr kPa
				MINIMUM FLOWRATE	MINIMUM FLOWRATE	MINIMUM DIAL RATE	MAX/ MIN FLOW RANGE	MINIMUM FLOWRATE	MINIMUM FLOWRATE	MINIMUM DIAL RATE	MAX/ MIN FLOW RANGE	
S=[Fpv] ²	kPa	Nm ³ /hr	Nm ³ /day	Nm ³ /hr	Nm ³ /day	m ³ /hr		Nm ³ /hr	Nm ³ /day	m ³ /hr		
1.0000	1.72	510	12,000	34	820	34	15	51	1,220	51	10	0.9
1.0008	34	680	16,000	40	950	29	17	54	1,290	40	13	1.3
1.0016	69	850	20,000	42	1,020	26	20	56	1,340	34	15	1.6
1.0024	103	1,020	24,000	48	1,160	24	21	58	1,390	29	18	1.9
1.0032	138	1,190	29,000	51	1,220	22	23	59	1,430	25	20	2.2
1.0040	172	1,360	33,000	57	1,360	21	24	61	1,460	23	23	2.5
1.0080	345	2,240	54,000	71	1,700	16	32	67	1,600	15	34	4.2
1.0121	517	3,140	75,000	85	2,040	14	37	71	1,700	11	44	5.7
1.0162	689	4,020	97,000	96	2,310	12	42	74	1,770	9.4	54	7.5
1.0203	862	4,930	118,000	105	2,520	11	47	77	1,840	7.9	64	9.2
1.0330	1,379	7,680	184,000	133	3,190	8.8	58	83	1,990	5.5	92	14
1.0502	2,068	11,440	275,000	161	3,870	7.1	71	89	2,150	4.0	128	21
1.0680	2,758	15,320	368,000	187	4,490	6.2	82	95	2,270	3.1	162	28
1.0863	3,447	19,340	464,000	210	5,030	5.7	92	111	2,660	2.9	175	36
1.1050	4,137	23,510	564,000	229	5,510	5.1	102	135	3,230	2.9	175	44
1.1241	4,826	27,780	667,000	252	6,050	4.5	110	159	3,820	2.9	175	52
1.1435	5,516	32,230	773,000	269	6,460	4.2	120	184	4,430	2.9	175	60
1.1630	6,205	36,820	884,000	289	6,930	4.0	127	211	5,060	2.9	175	68
1.1826	6,895	41,520	996,000	306	7,340	3.8	136	238	5,700	2.9	175	77
1.2021	7,584	46,360	1,113,000	323	7,750	3.7	144	265	6,370	2.9	175	86
1.2212	8,274	51,320	1,232,000	340	8,160	3.4	151	294	7,050	2.9	175	95
1.2397	8,963	56,390	1,353,000	357	8,560	3.3	158	323	7,750	2.9	175	105
1.2641	9,928	63,640	1,527,000	380	9,110	3.1	168	364	8,740	2.9	175	118

DN100 (G250) A100U45 meters of standard construction register 1 m³ per revolution of the mechanical output shaft

Table is based on IGU standard reference conditions of Pb=101.325 kPa and Tb=15° C, and average atmospheric pressure Pa=99.8 kPa.

Table incorporates effect of supercompressibility factor (Fpv) for 0.6 specific gravity natural gas at 15.6° C and 0% CO₂ and N₂ (per A.G.A. Report No. 8).

Notes: Maximum flowrate (dial rate) at flowing conditions is equal to 510 m³/hr, irrespective of the operating pressure (within the maximum allowable operating pressure of the meter).

DN100 (G400) A100U30 AUTO-ADJUST 30° ROTOR ANGLE (S.I. Units - cubic meters)

COMPRESSIBILITY RATIO	METER PRESSURE	MAXIMUM FLOWRATE	MAXIMUM FLOWRATE	Mechanical Output				Auto-Adjust Output				APPROX. PRESS LOSS @760 Nm ³ /hr kPa	(1)APPROX. PRESS LOSS @510 Nm ³ /hr kPa
				MINIMUM FLOWRATE	MINIMUM FLOWRATE	MINIMUM DIAL RATE	MAX/ MIN FLOW RANGE	MINIMUM FLOWRATE	MINIMUM FLOWRATE	MINIMUM DIAL RATE	MAX/ MIN FLOW RANGE		
S=[Fpv] ²	kPa	Nm ³ /hr	Nm ³ /day	Nm ³ /hr	Nm ³ /day	m ³ /hr		Nm ³ /hr	Nm ³ /day	m ³ /hr			
1.0000	1.72	760	18,000	51	1,220	51	15	76	1,840	76	10	1.9	0.88
1.0008	34	1,020	24,000	59	1,430	44	17	79	1,930	61	13	2.5	1.2
1.0016	69	1,270	31,000	65	1,560	40	20	85	2,010	50	15	3.0	1.5
1.0024	103	1,530	37,000	71	1,700	36	22	88	2,080	43	18	3.7	1.8
1.0032	138	1,780	43,000	79	1,900	33	23	88	2,140	38	20	4.5	2.1
1.0040	172	2,070	50,000	85	2,040	31	24	91	2,200	34	23	5.0	2.4
1.0080	345	3,370	81,000	108	2,580	24	31	99	2,400	23	34	8.2	4.0
1.0121	517	4,700	113,000	127	3,060	21	37	105	2,540	17	44	11	5.5
1.0162	689	6,030	145,000	144	3,470	18	42	110	2,670	14	54	15	7.0
1.0203	862	7,390	177,000	159	3,810	16	47	116	2,760	12	64	18	8.5
1.0330	1,379	11,500	276,000	198	4,760	13	58	125	2,990	8.3	92	28	13
1.0502	2,068	17,140	411,000	241	5,780	11	71	133	3,220	6.0	128	42	20
1.0680	2,758	22,970	551,000	280	6,730	9	82	142	3,390	4.7	163	56	26
1.0863	3,447	29,010	696,000	314	7,550	8	92	147	4,180	4.0	167	71	33
1.1050	4,137	35,270	846,000	346	8,290	8	102	153	5,080	4.0	167	86	40
1.1241	4,826	41,700	1,001,000	377	9,040	7	111	156	6,000	4.0	167	102	48
1.1435	5,516	48,360	1,161,000	405	9,720	7	119	161	6,960	4.0	167	118	55
1.1630	6,205	55,210	1,325,000	433	10,400	6	127	164	7,950	4.0	167	135	63
1.1826	6,895	62,290	1,495,000	459	11,010	6	136	170	8,970	4.0	167	152	71
1.2021	7,584	69,570	1,670,000	487	11,690	5	143	173	10,010	4.0	167	170	80
1.2212	8,274	77,020	1,849,000	513	12,310	5	150	176	11,090	4.0	167	188	88
1.2397	8,963	84,620	2,031,000	535	12,850	5	158	178	12,180	4.0	167	206	97
1.2641	9,928	95,470	2,291,000	569	13,670	5	168	181	13,750	4.0	167	233	109

DN100 (G400) A100U30 meters of standard construction register 1 m³ per revolution of the mechanical output shaft

(1) There is approximately 7% less pressure loss when compared to our A100U45 Turbo-Meter at 510 Nm³/hr.

Table is based on IGU standard reference conditions of Pb=101.325 kPa and Tb=15° C, and average atmospheric pressure Pa=99.8 kPa.

Table incorporates effect of supercompressibility factor (Fpv) for 0.6 specific gravity natural gas at 15.6° C and 0% CO₂ and N₂ (per A.G.A. Report No. 8).

Notes: Maximum flowrate (dial rate) at flowing conditions is equal to 760 m³/hr, irrespective of the operating pressure (within the maximum allowable operating pressure of the meter).

Performance ratings are based on +/- 1% measurement accuracy for all pressures and flowrates shown.

4" AAT-18 AUTO-ADJUST 45° ROTOR ANGLE (U.S. Units - cubic feet)

COMPRESSIBILITY RATIO	METER PRESSURE	MAXIMUM FLOWRATE	MAXIMUM FLOWRATE	Mechanical Output				Auto-Adjust Output				APPROX. PRESS LOSS INCHES W.C. @18000 ACFH
				MINIMUM FLOWRATE	MINIMUM FLOWRATE	MINIMUM DIAL RATE	MAX/MIN FLOW RANGE	MINIMUM FLOWRATE	MINIMUM FLOWRATE	MINIMUM DIAL RATE	MAX/MIN FLOW RANGE	
$S=[Fpv]^2$	PSIG	SCFH	MSCFD	SCFH	MSCFD	ACFH		SCFH	MSCFD	ACFH		
1.0000	0.25	18,000	430	1,200	29	1,200	15	1,800	43	1,800	10	3.8
1.0008	5	24,000	580	1,400	34	1,040	17	1,890	45	1,430	13	5.0
1.0016	10	30,000	720	1,500	36	930	20	1,970	47	1,185	15	6.3
1.0024	15	36,000	860	1,700	41	850	21	2,040	49	1,017	18	7.6
1.0032	20	42,000	1,010	1,800	43	780	23	2,100	50	894	20	8.9
1.0040	25	48,000	1,150	2,000	48	730	24	2,150	52	799	33	10
1.0080	50	79,000	1,900	2,500	60	570	32	2,350	56	533	34	17
1.0121	75	111,000	2,660	3,000	72	480	37	2,500	60	406	44	23
1.0162	100	142,000	3,410	3,400	82	430	42	2,610	63	331	54	30
1.0203	125	174,000	4,180	3,700	89	390	47	2,710	65	280	64	37
1.0330	200	271,000	6,500	4,700	113	310	58	2,930	70	195	92	57
1.0502	300	404,000	9,700	5,700	137	250	71	3,160	76	141	128	85
1.0680	400	541,000	12,980	6,600	158	220	82	3,340	80	111	162	114
1.0863	500	683,000	16,390	7,400	178	200	92	3,910	94	103	175	144
1.1050	600	830,000	19,920	8,100	194	180	102	4,750	114	103	175	175
1.1241	700	981,000	23,540	8,900	214	160	110	5,620	135	103	175	207
1.1435	800	1,138,000	27,310	9,500	228	150	120	6,510	156	103	175	240
1.1630	900	1,300,000	31,200	10,200	245	140	127	7,440	179	103	175	274
1.1826	1,000	1,466,000	35,180	10,800	259	135	136	8,390	201	103	175	310
1.2021	1,100	1,637,000	39,290	11,400	274	130	144	9,370	225	103	175	346
1.2212	1,200	1,812,000	43,490	12,000	288	120	151	10,370	249	103	175	383
1.2397	1,300	1,991,000	47,780	12,600	302	115	158	11,400	274	103	175	420
1.2641	1,440	2,247,000	53,930	13,400	322	110	168	12,860	309	103	175	474

4" Model AAT-18 meters of standard construction register 100 cubic feet per revolution of the mechanical output shaft

Table is based on base conditions of Pb=14.73 PSIA and Tb=60° F, and average atmospheric pressure Pa=14.48 PSIA.

Table incorporates effect of supercompressibility factor (Fpv) for 0.6 specific gravity natural gas at 60° F and 0% CO₂ and N₂ (per A.G.A. Report No. 8).

Notes: Maximum flowrate (dial rate) at flowing conditions is equal to 18,000 ACFH, irrespective of the operating pressure (within the maximum allowable operating pressure of the meter).

4" AAT-27 AUTO-ADJUST 30° ROTOR ANGLE (U.S. Units - cubic feet)

COMPRESSIBILITY RATIO	METER PRESSURE	MAXIMUM FLOWRATE	MAXIMUM FLOWRATE	Mechanical Output				Auto-Adjust Output				APPROX. PRESS LOSS INCHES W.C. @27000 ACFH	(1)APPROX. PRESS LOSS INCHES W.C. @18000 ACFH
				MINIMUM FLOWRATE	MINIMUM FLOWRATE	MINIMUM DIAL RATE	MAX/MIN FLOW RANGE	MINIMUM FLOWRATE	MINIMUM FLOWRATE	MINIMUM DIAL RATE	MAX/MIN FLOW RANGE		
$S=[Fpv]^2$	PSIG	SCFH	MSCFD	SCFH	MSCFD	ACFH		SCFH	MSCFD	ACFH			
1.0000	0.25	27,000	650	1,800	43	1,800	15	2,700	65	2,700	10	7.5	3.5
1.0008	5	36,000	860	2,100	50	1,560	17	2,840	68	2,146	13	9.9	4.7
1.0016	10	45,000	1,080	2,300	55	1,400	20	2,960	71	1,778	15	12	5.9
1.0024	15	54,000	1,300	2,500	60	1,270	22	3,060	73	1,526	18	15	7.1
1.0032	20	63,000	1,510	2,800	67	1,170	23	3,150	76	1,341	20	18	8.3
1.0040	25	73,000	1,750	3,000	72	1,100	24	3,230	78	1,199	23	20	9.5
1.0080	50	119,000	2,860	3,800	91	860	31	3,530	85	799	34	33	16
1.0121	75	166,000	3,980	4,500	108	730	37	3,740	90	609	44	46	22
1.0162	100	213,000	5,110	5,100	122	640	42	3,920	94	496	54	59	28
1.0203	125	261,000	6,260	5,600	134	580	47	4,060	97	420	64	72	34
1.0330	200	406,000	9,740	7,000	168	460	58	4,400	106	292	92	113	53
1.0502	300	605,000	14,520	8,500	204	380	71	4,730	114	211	128	168	79
1.0680	400	811,000	19,460	9,900	238	330	82	4,980	120	166	163	225	106
1.0863	500	1,024,000	24,580	11,100	266	290	92	6,150	148	162	167	285	134
1.1050	600	1,245,000	29,880	12,200	293	270	102	7,470	179	162	167	346	162
1.1241	700	1,472,000	35,330	13,300	319	240	111	8,830	212	162	167	409	192
1.1435	800	1,707,000	40,970	14,300	343	230	119	10,240	246	162	167	474	223
1.1630	900	1,949,000	46,780	15,300	367	210	127	11,700	281	162	167	542	254
1.1826	1,000	2,199,000	52,780	16,200	389	200	136	13,190	317	162	167	611	287
1.2021	1,100	2,456,000	58,940	17,200	413	190	143	14,730	354	162	167	682	320
1.2212	1,200	2,719,000	65,260	18,100	434	180	150	16,310	391	162	167	755	354
1.2397	1,300	2,987,000	71,690	18,900	454	170	158	17,920	430	162	167	830	389
1.2641	1,440	3,370,000	80,880	20,100	482	160	168	20,220	485	162	167	936	439

4" Model AAT-27 meters of standard construction register 100 cubic feet per revolution of the mechanical output shaft

(1) There is approximately 7% less pressure loss when compared to our AAT-18 Turbo-Meter at 18,000 ACFH.

Table is based on base conditions of Pb=14.73 PSIA and Tb=60° F, and average atmospheric pressure Pa=14.48 PSIA.

Table incorporates effect of supercompressibility factor (Fpv) for 0.6 specific gravity natural gas at 60° F and 0% CO₂ and N₂ (per A.G.A. Report No. 8).

Notes: Maximum flowrate (dial rate) at flowing conditions is equal to 27,000 ACFH, irrespective of the operating pressure (within the maximum allowable operating pressure of the meter).

DN150 (G650) A150U45 AUTO-ADJUST 45° ROTOR ANGLE (S.I. Units - cubic meters)

COMPRESSIBILITY RATIO	METER PRESSURE	MAXIMUM FLOWRATE	MAXIMUM FLOWRATE	Mechanical Output				Auto-Adjust Output				APPROX. PRESS LOSS @990 Nm ³ /hr kPa
				MINIMUM FLOWRATE	MINIMUM FLOWRATE	MINIMUM DIAL RATE	MAX/ MIN FLOW RANGE	MINIMUM FLOWRATE	MINIMUM FLOWRATE	MINIMUM DIAL RATE	MAX/ MIN FLOW RANGE	
$S=(Fpv)^2$	kPa	Nm ³ /hr	Nm ³ /day	Nm ³ /hr	Nm ³ /day	m ³ /hr		Nm ³ /hr	Nm ³ /day	m ³ /hr		
1.0000	1.72	990	24,000	50	1,190	50	20	99	2,380	99	10	0.8
1.0008	34	1,300	31,000	57	1,360	43	23	105	2,520	79	12	1.1
1.0016	69	1,640	39,000	65	1,560	39	25	108	2,580	65	15	1.5
1.0024	103	1,980	48,000	71	1,700	35	28	113	2,720	56	18	1.7
1.0032	138	2,320	56,000	76	1,840	32	30	116	2,790	49	20	2.0
1.0040	172	2,660	64,000	82	1,970	30	32	119	2,860	44	22	2.2
1.0080	345	4,360	105,000	105	2,520	24	42	130	3,130	29	33	3.7
1.0121	517	6,090	146,000	122	2,920	20	50	139	3,330	22	44	5
1.0162	689	7,820	188,000	139	3,330	18	56	144	3,470	18	54	7
1.0203	862	9,570	230,000	153	3,670	16	63	150	3,600	15	64	8
1.0330	1,379	14,900	357,000	193	4,620	13	77	161	3,880	11	92	13
1.0502	2,068	22,240	534,000	235	5,640	10	95	173	4,150	7.7	129	19
1.0680	2,758	29,800	715,000	272	6,530	9.1	110	184	4,420	6.1	162	25
1.0863	3,447	37,620	903,000	306	7,340	7.9	123	227	5,440	5.9	166	32
1.1050	4,137	45,690	1,097,000	337	8,090	7.4	136	275	6,590	5.9	166	39
1.1241	4,826	54,050	1,297,000	365	8,770	6.8	148	326	7,820	5.9	166	46
1.1435	5,516	62,690	1,505,000	394	9,450	6.2	159	377	9,040	5.9	166	53
1.1630	6,205	71,580	1,718,000	422	10,130	5.9	170	431	10,330	5.9	166	61
1.1826	6,895	80,760	1,938,000	448	10,740	5.4	180	484	11,630	5.9	167	69
1.2021	7,584	90,170	2,164,000	473	11,350	5.1	191	541	12,990	5.9	167	77
1.2212	8,274	99,830	2,396,000	499	11,970	4.8	200	598	14,350	5.9	167	85
1.2397	8,963	109,690	2,633,000	521	12,510	4.8	210	657	15,770	5.9	167	94
1.2641	9,928	123,770	2,970,000	555	13,330	4.5	223	742	17,810	5.9	167	106

DN150 (G650) A150U45 meters of standard construction register 1 m³ per revolution of the mechanical output shaft

Table is based on IGU standard reference conditions of Pb=101.325 kPa and Tb=15° C, and average atmospheric pressure Pa=99.8 kPa.

Table incorporates effect of supercompressibility factor (Fpv) for 0.6 specific gravity natural gas at 15.6° C and 0% CO₂ and N₂ (per A.G.A. Report No. 8).

Notes: Maximum flowrate (dial rate) at flowing conditions is equal to 990 m³/hr, irrespective of the operating pressure (within the maximum allowable operating pressure of the meter).

DN150 (G1000) A150U30 AUTO-ADJUST 30° ROTOR ANGLE (S.I. Units - cubic meters)

COMPRESSIBILITY RATIO	METER PRESSURE	MAXIMUM FLOWRATE	MAXIMUM FLOWRATE	Mechanical Output				Auto-Adjust Output				APPROX. PRESS LOSS @1610 Nm ³ /hr kPa	APPROX. PRESS LOSS @990 Nm ³ /hr kPa
				MINIMUM FLOWRATE	MINIMUM FLOWRATE	MINIMUM DIAL RATE	MAX/ MIN FLOW RANGE	MINIMUM FLOWRATE	MINIMUM FLOWRATE	MINIMUM DIAL RATE	MAX/ MIN FLOW RANGE		
$S=(Fpv)^2$	kPa	Nm ³ /hr	Nm ³ /day	Nm ³ /hr	Nm ³ /day	m ³ /hr		Nm ³ /hr	Nm ³ /day	m ³ /hr			
1.0000	1.72	1,610	39,000	81	1,940	81	20	161	3,880	161	10	2.1	0.85
1.0008	34	2,120	51,000	93	2,240	70	23	170	4,070	128	13	2.8	1.1
1.0016	69	2,690	65,000	105	2,520	63	26	177	4,250	106	15	3.5	1.4
1.0024	103	3,230	78,000	113	2,720	57	29	183	4,390	91	18	4.2	1.7
1.0032	138	3,800	91,000	125	2,990	53	30	188	4,520	80	20	4.9	2.0
1.0040	172	4,330	104,000	133	3,200	49	33	193	4,630	72	22	5.6	2.3
1.0080	345	7,140	171,000	170	4,080	39	42	211	5,070	48	34	9.2	3.7
1.0121	517	9,910	238,000	201	4,830	33	49	224	5,370	36	44	13	5.2
1.0162	689	12,750	306,000	227	5,440	29	56	234	5,620	30	54	16	6.7
1.0203	862	15,610	374,000	252	6,050	26	62	243	5,830	25	64	20	8.2
1.0330	1,379	24,280	583,000	314	7,550	21	77	263	6,320	17	92	31	13
1.0502	2,068	36,200	869,000	382	9,180	17	95	283	6,790	13	128	47	19
1.0680	2,758	48,530	1,165,000	442	10,610	15	110	300	7,190	10	162	63	25
1.0863	3,447	61,270	1,471,000	499	11,970	13	123	378	9,080	10	162	79	32
1.1050	4,137	74,420	1,786,000	547	13,120	12	136	460	11,030	10	162	96	39
1.1241	4,826	88,040	2,113,000	595	14,280	11	148	544	13,050	10	162	113	46
1.1435	5,516	102,090	2,450,000	643	15,430	10	159	631	15,130	10	162	132	53
1.1630	6,205	116,600	2,798,000	686	16,450	10	170	720	17,280	10	162	150	61
1.1826	6,895	131,530	3,157,000	728	17,470	9	181	812	19,490	10	162	169	69
1.2021	7,584	146,850	3,525,000	771	18,490	8	191	907	21,760	10	162	189	77
1.2212	8,274	162,570	3,902,000	810	19,440	8	201	1,004	24,090	10	162	209	85
1.2397	8,963	178,640	4,287,000	850	20,400	8	210	1,103	26,470	10	162	230	94
1.2641	9,928	201,550	4,837,000	901	21,620	7	224	1,245	29,870	10	162	260	106

DN150 (G1000) A150U30 meters of standard construction register 1 m³ per revolution of the mechanical output shaft

Table is based on IGU standard reference conditions of Pb=101.325 kPa and Tb=15° C, and average atmospheric pressure Pa=99.8 kPa.

Table incorporates effect of supercompressibility factor (Fpv) for 0.6 specific gravity natural gas at 15.6° C and 0% CO₂ and N₂ (per A.G.A. Report No. 8).

Notes: Maximum flowrate (dial rate) at flowing conditions is equal to 1,610 m³/hr, irrespective of the operating pressure (within the maximum allowable operating pressure of the meter).

Performance ratings are based on +/- 1% measurement accuracy for all pressures and flowrates shown.

6" AAT-35 AUTO-ADJUST 45° ROTOR ANGLE (U.S. Units - cubic feet)

COMPRESSIBILITY RATIO	METER PRESSURE	MAXIMUM FLOWRATE	MAXIMUM FLOWRATE	Mechanical Output				Auto-Adjust Output				APPROX. PRESS LOSS INCHES W.C. @35000 ACFH
				MINIMUM FLOWRATE	MINIMUM FLOWRATE	MINIMUM DIAL RATE	MAX/MIN FLOW RANGE	MINIMUM FLOWRATE	MINIMUM FLOWRATE	MINIMUM DIAL RATE	MAX/MIN FLOW RANGE	
$S=(Fpv)^2$	PSIG	SCFH	MSCFD	SCFH	MSCFD	ACFH		SCFH	MSCFD	ACFH		
1.0000	0.25	35,000	840	1,750	42	1,750	20	3,500	84	3,500	10	3.4
1.0008	5	46,000	1,100	2,000	48	1,520	23	3,700	89	2,781	12	4.5
1.0016	10	58,000	1,390	2,300	55	1,360	25	3,800	91	2,305	15	6
1.0024	15	70,000	1,680	2,500	60	1,240	28	4,000	96	1,978	18	7
1.0032	20	82,000	1,970	2,700	65	1,140	30	4,100	98	1,738	20	8
1.0040	25	94,000	2,260	2,900	70	1,070	32	4,200	101	1,554	22	9
1.0080	50	154,000	3,700	3,700	89	830	42	4,600	110	1,036	33	15
1.0121	75	215,000	5,160	4,300	103	710	50	4,900	118	789	44	21
1.0162	100	276,000	6,620	4,900	118	620	56	5,100	122	643	54	27
1.0203	125	338,000	8,110	5,400	130	560	63	5,300	127	545	64	33
1.0330	200	526,000	12,620	6,800	163	450	77	5,700	137	379	92	51
1.0502	300	785,000	18,840	8,300	199	370	95	6,100	146	273	129	76
1.0680	400	1,052,000	25,250	9,600	230	320	110	6,500	156	215	162	102
1.0863	500	1,328,000	31,870	10,800	259	280	123	8,000	192	210	166	129
1.1050	600	1,613,000	38,710	11,900	286	260	136	9,700	233	210	166	157
1.1241	700	1,908,000	45,790	12,900	310	240	148	11,500	276	210	166	185
1.1435	800	2,213,000	53,110	13,900	334	220	159	13,300	319	210	166	215
1.1630	900	2,527,000	60,650	14,900	358	210	170	15,200	365	210	166	245
1.1826	1,000	2,851,000	68,420	15,800	379	190	180	17,100	410	210	167	277
1.2021	1,100	3,183,000	76,390	16,700	401	180	191	19,100	458	210	167	309
1.2212	1,200	3,524,000	84,580	17,600	422	170	200	21,100	506	210	167	342
1.2397	1,300	3,872,000	92,930	18,400	442	170	210	23,200	557	210	167	376
1.2641	1,440	4,369,000	104,860	19,600	470	160	223	26,200	629	210	167	424

6" Model AAT-35 meters of standard construction register 100 cubic feet per revolution of the mechanical output shaft Table is based on base conditions of Pb=14.73 PSIA and Tb=60° F, and average atmospheric pressure Pa=14.48 PSIA. Table incorporates effect of supercompressibility factor (Fpv) for 0.6 specific gravity natural gas at 60° F and 0% CO₂ and N₂ (per A.G.A. Report No. 8).

Notes: Maximum flowrate (dial rate) at flowing conditions is equal to 35,000 ACFH, irrespective of the operating pressure (within the maximum allowable operating pressure of the meter).

6" AAT-57 AUTO-ADJUST 30° ROTOR ANGLE (U.S. Units - cubic feet)

COMPRESSIBILITY RATIO	METER PRESSURE	MAXIMUM FLOWRATE	MAXIMUM FLOWRATE	Mechanical Output				Auto-Adjust Output				APPROX. PRESS LOSS INCHES W.C. @57000 ACFH	APPROX. PRESS LOSS INCHES W.C. @35000 ACFH
				MINIMUM FLOWRATE	MINIMUM FLOWRATE	MINIMUM DIAL RATE	MAX/MIN FLOW RANGE	MINIMUM FLOWRATE	MINIMUM FLOWRATE	MINIMUM DIAL RATE	MAX/MIN FLOW RANGE		
$S=(Fpv)^2$	PSIG	SCFH	MSCFD	SCFH	MSCFD	SCFH		ACFH	MSCFD	ACFH			
1.0000	0.25	57,000	1,370	2,850	68	2,850	20	5,700	137	5,700	10	8.4	3.4
1.0008	5	75,000	1,800	3,300	79	2,480	23	5,990	144	4,530	13	11	4.5
1.0016	10	95,000	2,280	3,700	89	2,210	26	6,250	150	3,753	15	14	5.7
1.0024	15	114,000	2,740	4,000	96	2,010	29	6,460	155	3,221	18	17	6.8
1.0032	20	134,000	3,220	4,400	106	1,860	30	6,650	160	2,830	20	20	8.0
1.0040	25	153,000	3,670	4,700	113	1,740	33	6,810	163	2,531	22	22	9.1
1.0080	50	252,000	6,050	6,000	144	1,360	42	7,450	179	1,687	34	37	15
1.0121	75	350,000	8,400	7,100	170	1,150	49	7,900	190	1,286	44	51	21
1.0162	100	450,000	10,800	8,000	192	1,010	56	8,270	198	1,047	54	66	27
1.0203	125	551,000	13,220	8,900	214	920	62	8,570	206	887	64	81	33
1.0330	200	857,000	20,570	11,100	266	730	77	9,290	223	617	92	126	51
1.0502	300	1,278,000	30,670	13,500	324	600	95	9,980	240	445	128	187	76
1.0680	400	1,713,000	41,110	15,600	374	520	110	10,580	254	352	162	251	102
1.0863	500	2,163,000	51,910	17,600	422	460	123	13,360	321	352	162	317	129
1.1050	600	2,627,000	63,050	19,300	463	420	136	16,230	390	352	162	385	157
1.1241	700	3,108,000	74,590	21,000	504	390	148	19,190	461	352	162	456	185
1.1435	800	3,604,000	86,500	22,700	545	360	159	22,260	534	352	162	529	215
1.1630	900	4,116,000	98,780	24,200	581	340	170	25,420	610	352	162	604	245
1.1826	1,000	4,643,000	111,430	25,700	617	320	181	28,670	688	352	162	681	277
1.2021	1,100	5,184,000	124,420	27,200	653	300	191	32,010	768	352	162	760	309
1.2212	1,200	5,739,000	137,740	28,600	686	280	201	35,440	851	352	162	842	342
1.2397	1,300	6,306,000	151,340	30,000	720	270	210	38,940	935	352	162	925	376
1.2641	1,440	7,115,000	170,760	31,800	763	260	224	43,940	1,055	352	162	1044	424

6" Model AAT-57 meters of standard construction register 100 cubic feet per revolution of the mechanical output shaft Table is based on base conditions of Pb=14.73 PSIA and Tb=60° F, and average atmospheric pressure Pa=14.48 PSIA. Table incorporates effect of supercompressibility factor (Fpv) for 0.6 specific gravity natural gas at 60° F and 0% CO₂ and N₂ (per A.G.A. Report No. 8).

Notes: Maximum flowrate (dial rate) at flowing conditions is equal to 57,000 ACFH, irrespective of the operating pressure (within the maximum allowable operating pressure of the meter).

DN200 (G1000) A200U45 AUTO-ADJUST 45° ROTOR ANGLE (S.I. Units - cubic meters)

COMPRESSIBILITY RATIO	METER PRESSURE	MAXIMUM FLOWRATE	MAXIMUM FLOWRATE	Mechanical Output				Auto-Adjust Output				APPROX. PRESS LOSS @1700 Nm ³ /hr kPa
				MINIMUM FLOWRATE	MINIMUM FLOWRATE	MINIMUM DIAL RATE	MAX/ MIN FLOW RANGE	MINIMUM FLOWRATE	MINIMUM FLOWRATE	MINIMUM DIAL RATE	MAX/ MIN FLOW RANGE	
$S=(Fpv)^2$	kPa	Nm ³ /hr	Nm ³ /day	Nm ³ /hr	Nm ³ /day	m ³ /hr		Nm ³ /hr	Nm ³ /day	m ³ /hr		
1.0000	1.72	1,700	41,000	85	2,040	85	20	153	3,670	153	11	0.7
1.0008	34	2,240	54,000	99	2,380	74	23	159	3,810	119	14	0.2
1.0016	69	2,830	68,000	110	2,650	66	26	167	4,010	101	17	1.2
1.0024	103	3,400	82,000	119	2,860	60	29	173	4,150	86	20	1.4
1.0032	138	3,990	96,000	130	3,130	56	31	178	4,280	76	22	1.6
1.0040	172	4,560	109,000	139	3,330	52	33	184	4,420	68	25	1.9
1.0080	345	7,510	180,000	178	4,280	40	42	201	4,830	45	38	3.0
1.0121	517	10,450	251,000	210	5,030	34	50	212	5,100	34	49	4.2
1.0162	689	13,420	322,000	238	5,710	30	56	221	5,300	28	61	5.5
1.0203	862	16,430	394,000	263	6,320	27	62	229	5,510	24	71	6.7
1.0330	1,379	25,550	613,000	329	7,880	22	78	249	5,980	17	103	10
1.0502	2,068	38,100	914,000	402	9,650	18	95	269	6,460	12	142	16
1.0680	2,758	51,060	1,225,000	465	11,150	16	110	343	8,220	11	149	21
1.0863	3,447	64,460	1,547,000	524	12,570	14	123	433	10,400	11	149	26
1.1050	4,137	78,330	1,880,000	578	13,870	12	136	527	12,640	11	149	32
1.1241	4,826	92,630	2,223,000	629	15,090	12	147	623	14,950	11	149	38
1.1435	5,516	107,450	2,579,000	677	16,240	11	159	722	17,330	11	149	44
1.1630	6,205	122,680	2,944,000	722	17,330	10	170	827	19,850	11	149	50
1.1826	6,895	138,400	3,322,000	767	18,420	9.3	180	932	22,360	11	149	57
1.2021	7,584	154,450	3,709,000	810	19,440	8.8	191	1,039	24,940	11	149	64
1.2212	8,274	171,080	4,106,000	852	20,460	8.5	201	1,153	27,660	11	149	70
1.2397	8,963	188,000	4,512,000	895	21,480	8.2	210	1,266	30,380	11	149	77
1.2641	9,928	212,090	5,090,000	949	22,770	7.6	224	1,427	34,260	11	149	87

DN200 (G1000) A200U45 meters of standard construction register 10 m³ per revolution of the mechanical output shaft

Table is based on IGU standard reference conditions of Pb=101.325 kPa and Tb=15° C, and average atmospheric pressure Pa=99.8 kPa.

Table incorporates effect of supercompressibility factor (Fpv) for 0.6 specific gravity natural gas at 15.6° C and 0% CO₂ and N₂ (per A.G.A. Report No. 8).

Notes: Maximum flowrate (dial rate) at flowing conditions is equal to 1,700 m³/hr, irrespective of the operating pressure (within the maximum allowable operating pressure of the meter).

DN200 (G1600) A200U30 AUTO-ADJUST 30° ROTOR ANGLE (S.I. Units - cubic meters)

COMPRESSIBILITY RATIO	METER PRESSURE	MAXIMUM FLOWRATE	MAXIMUM FLOWRATE	Mechanical Output				Auto-Adjust Output				APPROX. PRESS LOSS @2550 Nm ³ /hr kPa	(1)APPROX. PRESS LOSS @1700 Nm ³ /hr kPa
				MINIMUM FLOWRATE	MINIMUM FLOWRATE	MIN DIAL RATE	MAX/ MIN FLOW RANGE	MINIMUM FLOWRATE	MINIMUM FLOWRATE	MINIMUM DIAL RATE	MAX/ MIN FLOW RANGE		
$S=(Fpv)^2$	kPa	Nm ³ /hr	Nm ³ /day	Nm ³ /hr	Nm ³ /day	m ³ /hr		Nm ³ /hr	Nm ³ /day	m ³ /hr			
1.0000	1.72	2,550	61,000	127	3,060	127	20	255	6,120	255	10	1.3	0.62
1.0008	34	3,370	81,000	147	3,540	111	23	269	6,440	203	13	1.8	0.82
1.0016	69	4,250	102,000	164	3,940	99	26	280	6,700	168	15	2.2	1.0
1.0024	103	5,130	123,000	181	4,350	90	28	289	6,930	144	18	2.7	1.2
1.0032	138	5,980	143,000	195	4,690	83	31	297	7,130	127	20	3.2	1.5
1.0040	172	6,860	165,000	210	5,030	78	33	306	7,320	113	22	3.7	1.7
1.0080	345	11,250	270,000	269	6,460	61	42	334	8,000	75	34	6.0	2.7
1.0121	517	15,670	376,000	317	7,610	51	49	354	8,480	57	44	8.3	3.7
1.0162	689	20,140	483,000	357	8,570	45	56	371	8,880	47	54	11	5.0
1.0203	862	24,650	591,000	397	9,520	41	62	382	9,210	40	64	13	6.0
1.0330	1,379	38,360	921,000	496	11,900	33	77	416	9,970	28	92	20	9.5
1.0502	2,068	57,170	1,372,000	603	14,480	27	95	448	10,710	20	128	30	14
1.0680	2,758	76,630	1,839,000	700	16,790	23	110	470	12,970	18	142	40	19
1.0863	3,447	96,740	2,322,000	785	18,830	21	123	490	16,380	18	142	51	24
1.1050	4,137	117,530	2,821,000	867	20,800	19	136	507	19,900	18	142	62	29
1.1241	4,826	139,010	3,336,000	940	22,570	17	148	524	23,540	18	142	73	34
1.1435	5,516	161,210	3,869,000	1,014	24,340	16	159	538	27,300	18	142	85	39
1.1630	6,205	184,080	4,418,000	1,082	25,970	15	170	550	31,170	18	142	97	45
1.1826	6,895	207,640	4,983,000	1,150	27,600	14	181	564	35,160	18	142	109	51
1.2021	7,584	231,890	5,565,000	1,215	29,170	13	191	575	39,260	18	142	122	56
1.2212	8,274	256,710	6,161,000	1,280	30,730	13	200	584	43,470	18	142	135	63
1.2397	8,963	282,060	6,770,000	1,340	32,160	12	211	595	47,760	18	142	149	69
1.2641	9,928	318,240	7,638,000	1,425	34,200	11	223	609	53,890	18	142	168	78

DN200 (G1600) A200U30 meters of standard construction register 10 m³ per revolution of the mechanical output shaft

(1) There is approximately 10% less pressure loss when compared to our A200U45 Turbo-Meter at 1,700 Nm³/hr.

Table is based on IGU standard reference conditions of Pb=101.325 kPa and Tb=15° C, and average atmospheric pressure Pa=99.8 kPa.

Table incorporates effect of supercompressibility factor (Fpv) for 0.6 specific gravity natural gas at 15.6° C and 0% CO₂ and N₂ (per A.G.A. Report No. 8).

Notes: Maximum flowrate (dial rate) at flowing conditions is equal to 2,550 m³/hr, irrespective of the operating pressure (within the maximum allowable operating pressure of the meter).

Performance ratings are based on +/- 1% measurement accuracy for all pressures and flowrates shown.

8" AAT-60 AUTO-ADJUST 45° ROTOR ANGLE (U.S. Units - cubic feet)

COMPRESSIBILITY RATIO	METER PRESSURE	MAXIMUM FLOWRATE	MAXIMUM FLOWRATE	Mechanical Output				Auto-Adjust Output				APPROX. PRESS LOSS INCHES W.C. @60000 ACFH
				MINIMUM FLOWRATE	MINIMUM FLOWRATE	MINIMUM DIAL RATE	MAX/ MIN FLOW RANGE	MINIMUM FLOWRATE	MINIMUM FLOWRATE	MINIMUM DIAL RATE	MAX/ MIN FLOW RANGE	
$S=[Fpv]^2$	PSIG	SCFH	MSCFD	SCFH	MSCFD	ACFH		SCFH	MSCFD	ACFH		
1.0000	0.25	60,000	1,440	3,000	72	3,000	20	5,400	130	5,400	11	2.8
1.0008	5	79,000	1,900	3,500	84	2,610	23	5,690	137	4,219	14	3.7
1.0016	10	100,000	2,400	3,900	94	2,330	26	5,900	142	3,556	17	4.7
1.0024	15	120,000	2,880	4,200	101	2,120	29	6,100	146	3,051	20	5.6
1.0032	20	141,000	3,380	4,600	110	1,960	31	6,300	151	2,681	22	6.6
1.0040	25	161,000	3,860	4,900	118	1,830	33	6,500	156	2,398	25	7.5
1.0080	50	265,000	6,360	6,300	151	1,430	42	7,100	170	1,599	38	12
1.0121	75	369,000	8,860	7,400	178	1,210	50	7,500	180	1,218	49	17
1.0162	100	474,000	11,380	8,400	202	1,070	56	7,800	187	992	60	22
1.0203	125	580,000	13,920	9,300	223	970	62	8,100	194	841	71	27
1.0330	200	902,000	21,650	11,600	278	770	78	8,880	211	585	103	42
1.0502	300	1,345,000	32,280	14,200	341	630	95	9,500	228	422	142	63
1.0680	400	1,803,000	43,270	16,400	394	550	110	12,100	290	404	149	84
1.0863	500	2,276,000	54,620	18,500	444	490	123	15,300	367	404	149	106
1.1050	600	2,766,000	66,380	20,400	490	440	136	18,600	446	404	149	129
1.1241	700	3,271,000	78,500	22,200	533	410	147	22,000	528	404	149	153
1.1435	800	3,794,000	91,060	23,900	574	380	159	25,500	612	404	149	177
1.1630	900	4,332,000	103,970	25,500	612	350	170	29,200	701	404	149	202
1.1826	1,000	4,887,000	117,290	27,100	650	330	180	32,900	790	404	149	228
1.2021	1,100	5,457,000	130,970	28,600	686	310	191	36,700	881	404	149	255
1.2212	1,200	6,041,000	144,980	30,100	722	300	201	40,700	977	404	149	282
1.2397	1,300	6,638,000	159,310	31,600	758	290	210	44,700	1,073	404	149	310
1.2641	1,440	7,489,000	179,740	33,500	804	270	224	50,400	1,210	404	149	349

8" Model AAT-60 meters of standard construction register 1000 cubic feet per revolution of the mechanical output shaft

Table is based on base conditions of Pb=14.73 PSIA and Tb=60° F, and average atmospheric pressure Pa=14.48 PSIA.

Table incorporates effect of supercompressibility factor (Fpv) for 0.6 specific gravity natural gas at 60° F and 0% CO₂ and N₂ (per A.G.A. Report No. 8).

Notes: Maximum flowrate (dial rate) at flowing conditions is equal to 60,000 ACFH, irrespective of the operating pressure (within the maximum allowable operating pressure of the meter).

8" AAT-90 AUTO-ADJUST 30° ROTOR ANGLE (U.S. Units - cubic feet)

COMPRESSIBILITY RATIO	METER PRESSURE	MAXIMUM FLOWRATE	MAXIMUM FLOWRATE	Mechanical Output				Auto-Adjust Output				APPROX. PRESS LOSS INCHES W.C. @90000 ACFH	(1)APPROX. PRESS LOSS INCHES W.C. @60000 ACFH
				MINIMUM FLOWRATE	MINIMUM FLOWRATE	MIN DIAL RATE	MAX/ MIN FLOW RANGE	MINIMUM FLOWRATE	MINIMUM FLOWRATE	MINIMUM DIAL RATE	MAX/ MIN FLOW RANGE		
$S=[Fpv]^2$	PSIG	SCFH	MSCFD	SCFH	MSCFD	ACFH		SCFH	MSCFD	ACFH			
1.0000	0.25	90,000	2,160	4,500	108	4,500	20	9,000	216	9,000	10	5.4	2.5
1.0008	5	119,000	2,860	5,200	125	3,910	23	9,470	227	7,152	13	7.1	3.3
1.0016	10	150,000	3,600	5,800	139	3,490	26	9,860	237	5,926	15	9.0	4.2
1.0024	15	181,000	4,340	6,400	154	3,180	28	10,200	245	5,085	18	11	5.0
1.0032	20	211,000	5,060	6,900	166	2,940	31	10,490	252	4,469	20	13	5.9
1.0040	25	242,000	5,810	7,400	178	2,740	33	10,760	258	3,997	22	15	6.7
1.0080	50	397,000	9,530	9,500	228	2,140	42	11,760	282	2,664	34	24	11
1.0121	75	553,000	13,270	11,200	269	1,810	49	12,480	300	2,030	44	33	15
1.0162	100	711,000	17,060	12,600	302	1,600	56	13,060	313	1,653	54	43	20
1.0203	125	870,000	20,880	14,000	336	1,450	62	13,540	325	1,401	64	52	24
1.0330	200	1,354,000	32,500	17,500	420	1,160	77	14,660	352	975	92	81	38
1.0502	300	2,018,000	48,430	21,300	511	950	95	15,750	378	703	128	121	56
1.0680	400	2,705,000	64,920	24,700	593	820	110	19,080	458	635	142	162	75
1.0863	500	3,415,000	81,960	27,700	665	730	123	24,090	578	635	142	205	95
1.1050	600	4,149,000	99,580	30,600	734	660	136	29,270	702	635	142	249	115
1.1241	700	4,907,000	117,770	33,200	797	610	148	34,620	831	635	142	294	136
1.1435	800	5,691,000	136,580	35,800	859	570	159	40,150	964	635	142	341	158
1.1630	900	6,498,000	155,950	38,200	917	530	170	45,850	1,100	635	142	390	181
1.1826	1,000	7,330,000	175,920	40,600	974	500	181	51,720	1,241	635	142	440	204
1.2021	1,100	8,186,000	196,460	42,900	1,030	470	191	57,750	1,386	635	142	491	227
1.2212	1,200	9,062,000	217,490	45,200	1,085	450	200	63,940	1,535	635	142	544	252
1.2397	1,300	9,957,000	238,970	47,300	1,135	430	211	70,250	1,686	635	142	597	277
1.2641	1,440	11,234,000	269,620	50,300	1,207	400	223	79,260	1,902	635	142	674	312

8" Model AAT-90 meters of standard construction register 1000 cubic feet per revolution of the mechanical output shaft

(1) There is approximately 10% less pressure loss when compared to our AAT-60 Turbo-Meter at 60,000 ACFH.

Table is based on base conditions of Pb=14.73 PSIA and Tb=60° F, and average atmospheric pressure Pa=14.48 PSIA.

Table incorporates effect of supercompressibility factor (Fpv) for 0.6 specific gravity natural gas at 60° F and 0% CO₂ and N₂ (per A.G.A. Report No. 8).

Notes: Maximum flowrate (dial rate) at flowing conditions is equal to 90,000 ACFH, irrespective of the operating pressure (within the maximum allowable operating pressure of the meter).

DN300 (G2500) A300U45 AUTO-ADJUST 45° ROTOR ANGLE (S.I. Units - cubic meters)

COMPRESSIBILITY RATIO	METER PRESSURE	MAXIMUM FLOWRATE	MAXIMUM FLOWRATE	Mechanical Output				Auto-Adjust Output				APPROX. PRESS LOSS @3970Nm ³ /hr kPa
				MINIMUM FLOWRATE	MINIMUM FLOWRATE	MINIMUM DIAL RATE	MAX/ MIN FLOW RANGE	MINIMUM FLOWRATE	MINIMUM FLOWRATE	MINIMUM DIAL RATE	MAX/ MIN FLOW RANGE	
S=[Fpv] ²	kPa	Nm ³ /hr	Nm ³ /day	Nm ³ /hr	Nm ³ /day	m ³ /hr		Nm ³ /hr	Nm ³ /day	m ³ /hr		
1.0000	1.72	3,970	95,000	159	3,810	159	25	396	9,500	396	10	0.7
1.0008	34	5,240	126,000	181	4,350	138	29	416	10,000	315	13	1.0
1.0016	69	6,600	158,000	204	4,890	123	32	433	10,400	261	15	1.2
1.0024	103	7,960	191,000	224	5,370	112	36	450	10,800	224	18	1.5
1.0032	138	9,320	224,000	244	5,850	103	38	462	11,100	197	20	1.7
1.0040	172	10,680	256,000	261	6,250	97	41	473	11,400	176	23	2.0
1.0080	345	17,500	420,000	334	8,020	76	52	518	12,400	117	34	3.2
1.0121	517	24,380	585,000	394	9,450	64	62	549	13,200	89	44	4.5
1.0162	689	31,320	752,000	445	10,670	56	70	575	13,800	73	55	6.0
1.0203	862	38,320	920,000	493	11,830	51	78	598	14,300	62	64	7.2
1.0330	1,379	59,640	1,431,000	615	14,750	41	97	646	15,500	43	92	11
1.0502	2,068	88,900	2,134,000	750	18,010	33	118	694	16,700	31	128	17
1.0680	2,758	119,140	2,859,000	869	20,870	29	137	731	17,500	24	163	22
1.0863	3,447	150,440	3,611,000	977	23,450	26	154	869	20,900	23	173	28
1.1050	4,137	182,780	4,387,000	1,076	25,830	24	170	1,054	25,300	23	173	34
1.1241	4,826	216,170	5,188,000	1,172	28,140	22	184	1,249	30,000	23	173	41
1.1435	5,516	250,690	6,017,000	1,260	30,250	20	199	1,447	34,700	23	173	47
1.1630	6,205	286,260	6,870,000	1,348	32,350	19	212	1,651	39,600	23	173	54
1.1826	6,895	322,930	7,750,000	1,430	34,320	18	226	1,863	44,700	23	173	61
1.2021	7,584	360,600	8,654,000	1,512	36,300	17	238	2,082	50,000	23	173	68
1.2212	8,274	399,200	9,581,000	1,592	38,200	16	251	2,305	55,300	23	173	75
1.2397	8,963	438,620	10,527,000	1,668	40,030	15	263	2,532	60,800	23	173	83
1.2641	9,928	495,890	11,877,000	1,773	42,550	14	279	2,857	68,600	23	173	93

DN300 (G2500) A300U45 meters of standard construction register 10 m³ per revolution of the mechanical output shaft

Table is based on IGU standard reference conditions of Pb=101.325 kPa and Tb=15° C, and average atmospheric pressure Pa=99.8 kPa.

Table incorporates effect of supercompressibility factor (Fpv) for 0.6 specific gravity natural gas at 15.6° C and 0% CO₂ and N₂ (per A.G.A. Report No. 8).

Notes: Maximum flowrate (dial rate) at flowing conditions is equal to 3,970 m³/hr, irrespective of the operating pressure (within the maximum allowable operating pressure of the meter).

DN300 (G4000) A300U30 AUTO-ADJUST 30° ROTOR ANGLE (S.I. Units - cubic meters)

COMPRESSIBILITY RATIO	METER PRESSURE	MAXIMUM FLOWRATE	MAXIMUM FLOWRATE	Mechanical Output				Auto-Adjust Output				APPROX. PRESS LOSS @6520 Nm ³ /hr kPa	(1)APPROX. PRESS LOSS @3970 Nm ³ /hr kPa
				MINIMUM FLOWRATE	MINIMUM FLOWRATE	MINIMUM DIAL RATE	MAX/ MIN FLOW RANGE	MINIMUM FLOWRATE	MINIMUM FLOWRATE	MINIMUM DIAL RATE	MAX/ MIN FLOW RANGE		
S=[Fpv] ²	kPa	Nm ³ /hr	Nm ³ /day	Nm ³ /hr	Nm ³ /day	m ³ /hr		Nm ³ /hr	Nm ³ /day	m ³ /hr			
1.0000	1.72	6,520	156,000	261	6,250	261	25	397	9,520	396	16	1.4	0.52
1.0008	34	8,610	207,000	300	7,210	227	29	416	10,010	315	21	1.8	0.69
1.0016	69	10,850	260,000	337	8,090	202	32	433	10,430	261	25	2.2	0.87
1.0024	103	13,060	313,000	368	8,840	184	35	450	10,790	224	29	2.7	1.0
1.0032	138	15,300	367,000	399	9,590	170	38	462	11,100	197	33	3.2	1.2
1.0040	172	17,540	421,000	428	10,270	159	41	473	11,370	176	37	3.7	1.4
1.0080	345	28,750	690,000	547	13,120	124	53	518	12,430	117	55	6.2	2.3
1.0121	517	40,060	961,000	646	15,500	105	62	550	13,200	89	73	9.0	3.2
1.0162	689	51,440	1,235,000	734	17,610	93	70	575	13,810	73	89	11	4.2
1.0203	862	62,940	1,511,000	810	19,440	84	78	598	14,320	62	106	13	5.0
1.0330	1,379	97,990	2,352,000	1,011	24,270	67	97	646	15,510	43	152	21	8.0
1.0502	2,068	146,090	3,506,000	1,235	29,640	55	118	694	20,630	31	170	31	12
1.0680	2,758	195,800	4,699,000	1,428	34,270	48	137	731	27,640	31	170	42	16
1.0863	3,447	247,220	5,933,000	1,606	38,550	42	154	762	34,900	31	170	53	20
1.1050	4,137	300,330	7,208,000	1,770	42,490	39	170	790	42,400	31	170	64	24
1.1241	4,826	355,260	8,526,000	1,923	46,160	35	185	816	50,150	31	170	76	29
1.1435	5,516	411,970	9,887,000	2,074	49,770	33	199	836	58,160	31	170	88	33
1.1630	6,205	470,440	11,291,000	2,215	53,170	31	212	856	66,420	31	170	101	38
1.1826	6,895	530,670	12,736,000	2,351	56,430	29	226	875	74,920	31	170	113	43
1.2021	7,584	592,590	14,222,000	2,484	59,620	27	239	892	83,670	31	170	127	48
1.2212	8,274	656,020	15,744,000	2,615	62,750	26	251	909	92,620	31	170	140	53
1.2397	8,963	720,810	17,299,000	2,742	65,810	25	263	926	101,760	31	170	154	58
1.2641	9,928	813,270	19,519,000	2,912	69,890	23	279	946	114,820	31	170	174	65

DN300 (G4000) A300U30 meters of standard construction register 10 m³ per revolution of the mechanical output shaft

(1) There is approximately 30% less pressure loss when compared to our A300U45 Turbo-Meter at 3970 m³/hr.

Table is based on IGU standard reference conditions of Pb=101.325 kPa and Tb=15° C, and average atmospheric pressure Pa=99.8 kPa.

Table incorporates effect of supercompressibility factor (Fpv) for 0.6 specific gravity natural gas at 15.6° C and 0% CO₂ and N₂ (per A.G.A. Report No. 8).

Notes: Maximum flowrate (dial rate) at flowing conditions is equal to 6,520 m³/hr, irrespective of the operating pressure (within the maximum allowable operating pressure of the meter).

Performance ratings are based on +/- 1% measurement accuracy for all pressures and flowrates shown.

12" AAT-140 AUTO-ADJUST 45° ROTOR ANGLE (U.S. Units - cubic feet)

COMPRESSIBILITY RATIO	METER PRESSURE	MAXIMUM FLOWRATE	MAXIMUM FLOWRATE	Mechanical Output				Auto-Adjust Output				APPROX PRESS LOSS INCHES W.C. @140000 ACFH
				MINIMUM FLOWRATE	MINIMUM FLOWRATE	MINIMUM DIAL RATE	MAX/ MIN FLOW RANGE	MINIMUM FLOWRATE	MINIMUM FLOWRATE	MINIMUM DIAL RATE	MAX/ MIN FLOW RANGE	
$S=(Fpv)^2$	PSIG	SCFH	MSCFD	SCFH	MSCFD	ACFH		SCFH	MSCFD	ACFH		
1.0000	0.25	140,000	3,360	5,600	134	5,600	25	14,000	336	14,000	10	3.0
1.0008	5	185,000	4,440	6,400	154	4,870	29	14,700	353	11,125	13	4.0
1.0016	10	233,000	5,590	7,200	173	4,340	32	15,300	367	9,218	15	5.0
1.0024	15	281,000	6,740	7,900	190	3,950	36	15,900	382	7,910	18	6.0
1.0032	20	329,000	7,900	8,600	206	3,650	38	16,300	391	6,952	20	7.0
1.0040	25	377,000	9,050	9,200	221	3,410	41	16,700	401	6,217	23	8.1
1.0080	50	618,000	14,830	11,800	283	2,670	52	18,300	439	4,145	34	13
1.0121	75	861,000	20,660	13,900	334	2,260	62	19,400	466	3,158	44	18
1.0162	100	1,106,000	26,540	15,700	377	1,990	70	20,300	487	2,571	54	24
1.0203	125	1,353,000	32,470	17,400	418	1,800	78	21,100	506	2,180	64	29
1.0330	200	2,106,000	50,540	21,700	521	1,440	97	22,800	547	1,516	92	45
1.0502	300	3,139,000	75,340	26,500	636	1,180	118	24,500	588	1,093	128	67
1.0680	400	4,207,000	100,970	30,700	737	1,020	137	25,800	619	860	163	90
1.0863	500	5,312,000	127,490	34,500	828	910	154	30,700	737	808	173	114
1.1050	600	6,454,000	154,900	38,000	912	830	170	37,200	893	808	173	138
1.1241	700	7,633,000	183,190	41,400	994	760	184	44,100	1,058	808	173	164
1.1435	800	8,852,000	212,450	44,500	1,068	700	199	51,100	1,226	808	173	190
1.1630	900	10,108,000	242,590	47,600	1,142	660	212	58,300	1,399	808	173	217
1.1826	1,000	11,403,000	273,670	50,500	1,212	620	226	65,800	1,579	808	173	244
1.2021	1,100	12,733,000	305,590	53,400	1,282	590	238	73,500	1,764	808	173	273
1.2212	1,200	14,096,000	338,300	56,200	1,349	560	251	81,400	1,954	808	173	302
1.2397	1,300	15,488,000	371,710	58,900	1,414	530	263	89,400	2,146	808	173	332
1.2641	1,440	17,475,000	419,400	62,600	1,502	500	279	100,900	2,422	808	173	374

12" Model AAT-140 meters of standard construction register 1000 cubic feet per revolution of the mechanical output shaft

Table is based on base conditions of Pb=14.73 PSIA and Tb=60° F, and average atmospheric pressure Pa=14.48 PSIA.

Table incorporates effect of supercompressibility factor (Fpv) for 0.6 specific gravity natural gas at 60° F and 0% CO₂ and N₂ (per A.G.A. Report No. 8).

Notes: Maximum flowrate (dial rate) at flowing conditions is equal to 140,000 ACFH, irrespective of the operating pressure (within the maximum allowable operating pressure of the meter).

12" AAT-230 AUTO-ADJUST 30° ROTOR ANGLE (U.S. Units - cubic feet)

COMPRESSIBILITY RATIO	METER PRESSURE	MAXIMUM FLOWRATE	MAXIMUM FLOWRATE	Mechanical Output				Auto-Adjust Output				APPROX. PRESS LOSS INCHES W.C. @230000 ACFH	(1) APPROX. PRESS LOSS INCHES W.C. @140000 ACFH
				MINIMUM FLOWRATE	MINIMUM FLOWRATE	MINIMUM DIAL RATE	MAX/ MIN FLOW RANGE	MINIMUM FLOWRATE	MINIMUM FLOWRATE	MINIMUM DIAL RATE	MAX/ MIN FLOW RANGE		
$S=(Fpv)^2$	PSIG	SCFH	MSCFD	SCFH	MSCFD	ACFH		SCFH	MSCFD	ACFH			
1.0000	0.25	230,000	5,520	9,200	221	9,200	25	14,000	336	14,000	16	5.6	2.1
1.0008	5	304,000	7,300	10,600	254	8,000	29	14,720	353	11,125	21	7.4	2.8
1.0016	10	383,000	9,190	11,900	286	7,130	32	15,340	368	9,218	25	9.0	3.5
1.0024	15	461,000	11,060	13,000	312	6,500	35	15,870	381	7,910	29	11	4.2
1.0032	20	540,000	12,960	14,100	338	6,000	38	16,330	392	6,952	33	13	4.9
1.0040	25	619,000	14,860	15,100	362	5,610	41	16,730	402	6,217	37	15	5.7
1.0080	50	1,015,000	24,360	19,300	463	4,380	53	18,290	439	4,145	55	25	9.3
1.0121	75	1,414,000	33,940	22,800	547	3,710	62	19,410	466	3,158	73	34	13
1.0162	100	1,816,000	43,580	25,900	622	3,270	70	20,310	487	2,571	89	44	17
1.0203	125	2,222,000	53,330	28,600	686	2,960	78	21,060	505	2,180	106	54	20
1.0330	200	3,459,000	83,020	35,700	857	2,370	97	22,810	547	1,516	152	84	32
1.0502	300	5,157,000	123,770	43,600	1,046	1,940	118	30,340	728	1,353	170	126	47
1.0680	400	6,912,000	165,890	50,400	1,210	1,680	137	40,660	976	1,353	170	168	63
1.0863	500	8,727,000	209,450	56,700	1,361	1,490	154	51,330	1,232	1,353	170	212	80
1.1050	600	10,602,000	254,450	62,500	1,500	1,360	170	62,370	1,497	1,353	170	258	97
1.1241	700	12,541,000	300,980	67,900	1,630	1,250	185	73,770	1,770	1,353	170	305	115
1.1435	800	14,543,000	349,030	73,200	1,757	1,160	199	85,550	2,053	1,353	170	354	133
1.1630	900	16,607,000	398,570	78,200	1,877	1,080	212	97,690	2,345	1,353	170	404	152
1.1826	1,000	18,733,000	449,590	83,000	1,992	1,020	226	110,200	2,645	1,353	170	456	171
1.2021	1,100	20,919,000	502,060	87,700	2,105	960	239	123,060	2,953	1,353	170	509	191
1.2212	1,200	23,158,000	555,790	92,300	2,215	920	251	136,230	3,270	1,353	170	564	211
1.2397	1,300	25,445,000	610,680	96,800	2,323	870	263	149,680	3,592	1,353	170	620	232
1.2641	1,440	28,709,000	689,020	102,800	2,467	820	279	168,880	4,053	1,353	170	699	262

12" Model AAT-230 meters of standard construction register 1000 cubic feet per revolution of the mechanical output shaft

(1) There is approximately 30% less pressure loss when compared to our AAT-140 Turbo-Meter at 140,000 ACFH.

Table is based on base conditions of Pb=14.73 PSIA and Tb=60° F, and average atmospheric pressure Pa=14.48 PSIA.

Table incorporates effect of supercompressibility factor (Fpv) for 0.6 specific gravity natural gas at 60° F and 0% CO₂ and N₂ (per A.G.A. Report No. 8).

Notes: Maximum flowrate (dial rate) at flowing conditions is equal to 230,000 ACFH, irrespective of the operating pressure (within the maximum allowable operating pressure of the meter).

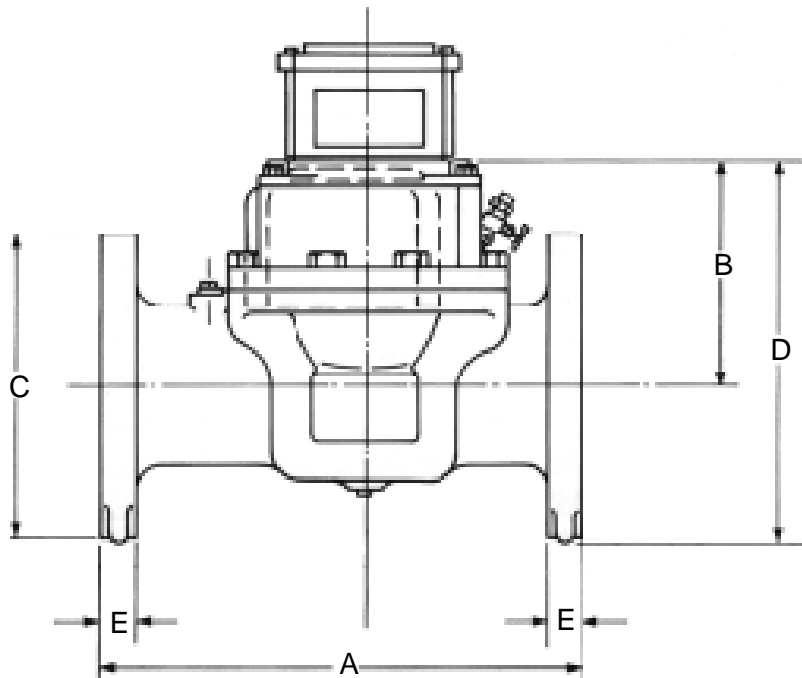

100mm Model A100U45/30

(Dimension in millimeters)

BODY MATERIAL	Maximum Allowable Working Pressure MAOP (bar)	Dimension (mm)				
		A	B	C	D	E
Ductile Iron/ISO PN20	16	300	271	232	387	27
Steel/ISO PN50	50	300	277	259	406	37
Steel/ISO PN110	100	300	277	277	415	51

150mm Model A150U45/30

(Dimension in millimeters)

BODY MATERIAL	Maximum Allowable Working Pressure MAOP (bar)	Dimension (mm)				
		A	B	C	D	E
Ductile Iron/ISO PN20	16	450	218	287	362	26
Steel/ISO PN50	50	450	225	325	369	37
Steel/ISO PN110	100	450	225	360	405	56

200mm Model A200U45/30

(Dimension in millimeters)

BODY MATERIAL	Maximum Allowable Working Pressure MAOP (bar)	Dimension (mm)				
		A	B	C	D	E
Ductile Iron/ISO PN20	16	600	249	345	422	29
Steel/ISO PN50	50	600	262	386	455	42
Steel/ISO PN100	100	600	262	435	480	56

300mm Model A300U45/30

(Dimension in millimeters)

BODY MATERIAL	Maximum Allowable Working Pressure MAOP (bar)	Dimension (mm)				
		A	B	C	D	E
Ductile Iron/ISO PN20	16	900	320	485	573	32
Steel/ISO PN50	50	900	330	520	590	51
Steel/ISO PN100	100	900	330	560	610	67

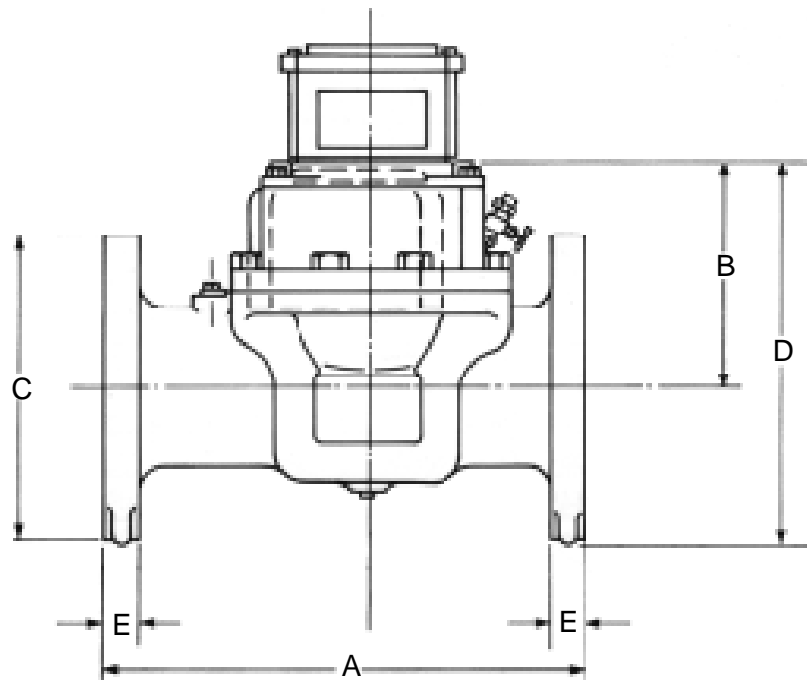

4" Model AAT-18/27

(Dimension in inches)

BODY MATERIAL	Maximum Allowable Working Pressure MAOP (psig)	Dimension (inches)				
		A	B	C	D	E
Ductile Iron/ ANSI 150	240	11 ¹³ / ₁₆	10 ⁵ / ₈	9 ³ / ₁₆	15 ¹ / ₄	1 ¹ / ₁₆
Steel ANSI 300	720	11 ¹³ / ₁₆	10 ¹⁵ / ₁₆	10 ³ / ₁₆	16	1 ⁷ / ₁₆
Steel ANSI 600	1440	11 ¹³ / ₁₆	10 ¹⁵ / ₁₆	10 ⁷ / ₈	16 ³ / ₈	2

6" Model AAT-35/57

(Dimension in inches)

BODY MATERIAL	Maximum Allowable Working Pressure MAOP (psig)	Dimension (inches)				
		A	B	C	D	E
Ductile Iron/ ANSI 150	240	17 ³ / ₄	8 ⁵ / ₈	11 ⁵ / ₁₆	14 ¹ / ₄	1
Steel ANSI 300	720	17 ³ / ₄	8 ⁷ / ₈	12 ³ / ₄	14 ⁹ / ₁₆	1 ⁷ / ₁₆
Steel ANSI 600	1440	17 ³ / ₄	8 ⁷ / ₈	14 ³ / ₁₆	15 ¹⁵ / ₁₆	2 ³ / ₁₆

8" Model AAT-60/90

(Dimension in inches)

BODY MATERIAL	Maximum Allowable Working Pressure MAOP (psig)	Dimension (inches)				
		A	B	C	D	E
Ductile Iron/ ANSI 150	240	23 ⁵ / ₈	9 ¹ / ₁₆	13 ⁵ / ₈	16 ⁵ / ₈	1 ⁵ / ₁₆
Steel ANSI 300	720	23 ⁵ / ₈	10 ⁵ / ₁₆	15 ³ / ₁₆	17 ⁷ / ₈	1 ⁵ / ₈
Steel ANSI 600	1440	23 ⁵ / ₈	10 ⁵ / ₈	17 ¹ / ₈	18 ⁷ / ₈	2 ³ / ₁₆

12" Model AAT-140/230

(Dimension in inches)

BODY MATERIAL	Maximum Allowable Working Pressure MAOP (psig)	Dimension (inches)				
		A	B	C	D	E
Ductile Iron/ ANSI 150	240	35 ⁷ / ₁₆	12 ⁵ / ₈	19	22 ¹ / ₈	1 ¹ / ₄
Steel ANSI 300	720	35 ⁷ / ₁₆	13	20 ¹ / ₂	23 ¹ / ₄	2
Steel ANSI 600	1440	35 ⁷ / ₁₆	13	22	24	2 ⁷ / ₁₆

Get the Most From Your AAT!

Custom and Scheduled Auto-Adjust Training

Equimeter's dedicated staff of technical services engineers conducts customized training programs for Auto-Adjust Turbo-Meters.

Known as AATMUS (Auto-Adjust Turbo-Meter Users Symposium), the program trains existing and prospective customers in the principles underlying the design of AAT-Meters. From these principles evolve recommendations for installation, maintenance and operation as prescribed by Equimeter's design team. Details on AATMUS training follow:

Who Should Attend:

- Managers and supervisors of Measurement Departments
- Measurement engineers responsible for specification, design, or operation of custody transfer measurement equipment
- Operations personnel responsible for flow measurement, the operation of measurement systems, or for field service of custody transfer measurement equipment
- Those interested in reducing unaccounted-for gas

A Sampling of AATMUS Topics:

- Basic turbine meter theory and performance
- Theory and operating principles of the Auto-Adjust Turbo-Meter System
- Performance of Auto-Adjust Turbo-Meters under various operating conditions
- Typical AAT savings
- Construction and design features of the AAT
- AAT Electronics overview
- Sizing, installation, operation, field check, and maintenance of the AAT
- AutoCorrector, SER, and Field Prover principles and operation
- Auto-Adjust Meter and electronics workshops



How to Let Us Know You're Interested in Attending an AATMUS

Please fill out the following response form, photocopy, and mail or fax it to Equimeter's Technical Service & Training Department. We will respond with a complete program, a registration form and information on accommodations.

Yes, I am interested in receiving more information regarding upcoming Auto-Adjust Turbo-Meter Users Symposiums.

Name _____ Title _____

Company Name _____

Address _____

City _____ State/Pro _____

Country _____ Postal Code _____

Telephone _____ Fax _____

Email _____

Equimeter Incorporated 001+1+(814) 371-8000 Fax 001+1+(814) 375-8460

Customized Technical Training Programs

For information on customized measurement, pressure regulation, or volume correction training by Equimeter's technical services engineers, please contact the Technical Services and Training Department.

High Pressure Calibration Facilities

In parallel with the development of the broad product line of Turbo-Meters, Equimeter also engineered and installed one of the most technologically sophisticated and accurate large-volume, high-pressure meter calibration facilities in the world. Repeated correlation tests with other large-volume meter proving facilities, using various flowing media and different reference standards, have verified the accuracy of Equimeter Turbo-Meter calibrations.

Each Turbo-Meter produced receives a low-pressure calibration test at five different flowrates.

A computer-generated performance curve plus relevant numerical calibration data are furnished with each meter. For elevated pressure installations, at user request, Equimeter will provide calibration data at the desired operating pressure and flowrates. Published flowrates are based on $\pm 1\%$ accuracy of measurement.



14.2 m³ (500 ft³) Proving Bell



High Pressure Flow Loop; up to 62 bar (900 psi)

ABOUT EQUIMETER

Equimeter has been a leading supplier of gas meters, metering systems, instrumentation for gas meters, and pressure regulation equipment since 1886. The company's technological contributions to gas measurement advancement trace over 110 years. Today, millions of Equimeter gas meters are in service on all types of gas measurement applications, ranging from high-pressure, off-shore producing platforms to multi-tenant dwellings. A wide range of Equimeter's electronic instruments perform pressure and temperature correction, as well as data acquisition with many of these measurement systems.

Equimeter is a subsidiary company of Invensys, a leading international provider of measurement products and systems solutions. Invensys is a highly successful, worldwide engineering group with operations on every continent.

From our facilities in DuBois, Pennsylvania, Equimeter combines highly sophisticated, automated machinery with professional craftsmanship to assure strict quality manufacturing.

Equimeter's global reach extends from its DuBois headquarters through its external support groups. International sales, marketing, customer and technical services, finance, and administration are all centrally located with the manufacturing facilities. An accomplished staff of product and research engineers continues to explore exciting innovations for the world of gas measurement, pressure regulation and electronic volume correction from a state-of-the-art engineering services laboratory, and through extensive field studies.

A network of authorized distributors in key geographic locations worldwide represents Equimeter products and services through their own highly trained experts.

Our certification to **ISO-9001**, an internationally recognized quality standard, offers our customers:

- Uniformity of products and processes
- Improved quality awareness throughout Equimeter
- Strengthened supplier and customer confidence
- A foundation for building Total Quality Management principles
- Broadened technical expertise (by providing Equimeter opportunities to enter new markets)



Equimeter headquarters in DuBois, Pennsylvania

Contact your local representative for more information on Equimeter or visit our website at www.equimeter.com.



R-275 Meter



Intermediate & Large Capacity Diaphragm Meters



Mark IIE Turbo-Meters



Mark II Turbo-Meter

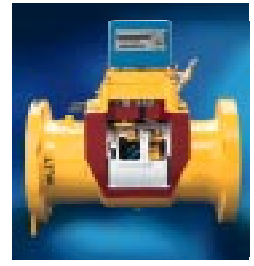

Auto-Adjust II Turbo-Meter

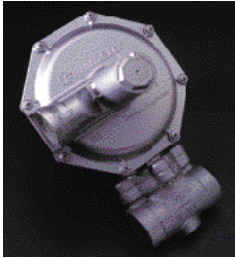

Model 143-6 Service Regulator



Model 122 Industrial Combustion Regulator



Model 441-S Large Capacity Regulator



Model 257-Safety Relief Valve



Auto-Adjust/AutoCorrector Measurement System



NexCorr Volume Corrector



TELUS Data Management & Communications Software

Authorized Distributor:



805 Liberty Boulevard
P.O. Box 528
DuBois, PA 15801
001+1+ (814) 371-8000
Fax 001+1+(814) 375-8460
www.equimeter.com

An Invensys Company

All products purchased and services performed are subject to Sensus' terms of sale, available at either; <http://na.sensus.com/TC/TermsConditions.pdf> or 1-800-METER-IT. Sensus reserves the right to modify these terms and conditions in its own discretion without notice to the customer.

This document is for informational purposes only, and SENSUS MAKES NO EXPRESS WARRANTIES IN THIS DOCUMENT. FURTHERMORE, THERE ARE NO IMPLIED WARRANTIES, INCLUDING WITHOUT LIMITATION, WARRANTIES AS TO FITNESS FOR A PARTICULAR PURPOSE AND MERCHANTABILITY. ANY USE OF THE PRODUCTS THAT IS NOT SPECIFICALLY PERMITTED HEREIN IS PROHIBITED.