

# Model 441-S Regulator

## Installation and Maintenance Instructions

### Introduction

#### Maximum Inlet Pressures

Regulator Body Type	441 Body Materials	Max. Working Pressure Of Body	Max. Inlet Pressure
Screwed End (2" Pipe Size Only)	Cast Iron (ASTM A126-71 Class B)	250 psi	100 psi
Flanged ANSI 125 FF	Cast Iron (ASTM A126-71 Class B)	175 psi	
Flanged ANSI 250 RF	Ductile Iron (ASTM A395-71 gr 60-40-18)	575 psi	
Flanged ANSI 300 RF	Cast Steel (ASTM A126-70a gr WCB)	720 psi	

#### Installation and Start-Up

- Thoroughly purge inlet piping to remove dirt and debris which could damage the regulator or impair its operation. If this cannot be done, a filter or strainer should be installed ahead of the regulator.  
Make certain regulator is free of any dirt or foreign matter that might have collected.
- Place regulator in the line with high pressure connected to the inlet side (be sure shipping screens or covers, if used, are removed from the inlet and outlet).  
Tighten bolts on flanges evenly.  
Where required, the regulator may be inverted.



#### CAUTION

It is the user's responsibility to ensure that all regulator vents and/or vent lines exhaust to a non-hazardous location away from ANY POTENTIAL sources of ignition. Where vent lines are used, it is the user's responsibility to ensure that each regulator is individually vented and that common vent lines ARE NOT used.

- From the 1/2" union **60** extend pipe or tubing to the control connection into the outlet piping. This control piping should not be less than 1/2" in size and should be adequately protected against breakage (regulators go wide open if the control line is broken).  
The regulator will work to deliver the pressure, for which it is adjusted, at that point in the outlet piping where the control connection is located.  
In general, the control connection should be at least 8 pipe diameters from the regulator and should be in as straight a run of pipe as possible.  
The control connection should be clean and smooth, free of rough edges, welding "icicles". etc.
- Where outlet piping increases in size near the regulator, it is generally preferable to locate the control connection in the larger size.  
The 1/2" union **60** contains a small orifice, approximately 1/16" diameter. This orifice should not be removed. Also, make certain this orifice is open and free of foreign material.  
Check all connections for leaks.



#### CAUTION

Turn gas on very slowly. If an outlet stop valve is used, it should be opened first. Do not overload the diaphragm with a sudden surge of inlet pressure. Monitor the outlet pressure during start-up to prevent an outlet pressure overload.

- Put the regulator into operation as follows: (refer to page 6)
  - Slowly open the downstream control line valve (A).
  - Slowly open the downstream block valve (B).
  - Very slowly open the upstream block valve (C).
  - Set the adjusting screw **10** for the required outlet pressure. Turn it clockwise to increase the pressure counterclockwise to decrease it. Only make this adjustment when gas is actually flowing through the regulator.
  - After adjustment is complete, the lock nut **11** should be tightened firmly and the seal cap **1** replaced.
- To shut down, carefully close valves **C**, **B**, and **A** in that order.



#### CAUTION

The diaphragm case vent must be positioned to protect against flooding, drain water, ice formation, traffic, tampering, etc. The vent must be protected against nest building animals, bees, insects, etc. to prevent vent blockage and minimize the chances of foreign material collecting in the vent side of the regulator diaphragm.

- The vent connection is an escape path for flammable gas and it must be located and/or piped so that potential discharge occurs in a safe area away from buildings, open flames, collection areas, arcing devices, etc.  
**Regulators installed indoors or in a non-vented area must be vented to the outside. Simply run vent piping from the regulator vent connection to a non-hazardous location on the outside away from ANY POTENTIAL sources of ignition. The vent piping must be connection size or larger and piped to a safe area. The vent discharge must be protected against the potentials outlined in instructions #2 and #10.**
- For outdoor installations, it is recommended the regulator be installed so the regulator vent faces downward to avoid the potential for water or other foreign matter entering the regulator and interfering with the proper operation of the regulator.

### Servicing and Adjustment

#### General Notes

- Make sure the regulator is entirely depressured before servicing.
- A quick visual inspection of the valve can be made by removing inspection plates **38** from the sides of the body.  
They also provide greatly improved access to the valve when servicing or adjusting.
- The valve and body parts are interchangeable with other 441 Regulators (441-57S, 441-X57, 441-VPC, 441-2100, etc.).

- Use lubricants sparingly and with care to avoid exposing tacky surfaces to the gas stream. Such surfaces could cause accumulation of dirt on close clearance parts.

**Use moly or silicone-type lubricants. Avoid the use of petroleum base types.**

Lubricate stem **24**, guide **50h**, and stem O-ring **23** with dry silicone lubricant to help ensure free movement and a tight seal.

An application of lubricant to the other O-rings and the tetraseals in the regulator will help ensure their tightness.

### To Remove Valves

- Remove seal cap **1**, back off adjusting screw **10**, remove housing cover **5**, and spring **14**.
- Remove bottom plate **33**, and side plates **38**.
- Insert an Allen wrench through side inspection opening and loosen Allen screw **50h**.
- Unscrew lower valve assembly and remove through bottom opening (**50h** unscrews from **24**).
- Unscrew upper valve assembly and remove through side opening (**50e** or **50j** unscrews from **24**).

**NOTE:**

- If upper valve assembly is too large to remove through side opening, remove it through bottom opening by also removing outlet orifice **29**, (remove cap screws **26** to remove orifice, and, if tight, jack out using cap screws in jacking holes).
  - Entire valve assembly may be removed intact through bottom opening by also removing orifice **29**. This method leaves the lock-up adjustment undisturbed.
  - Use care with orifice gasket **27**.
- To disassemble upper and/or lower valve assembly, remove nuts **50a**.

### To Replace and Adjust Valves

- Assemble upper valve assembly (parts **50a**, **50b**, **50c**, **50d**, **50e**, **50f**, **50g**, **50j**), and lower valve assembly (parts **50a**, **50b**, **50c**, **50d**, **50h**). Firmly tighten nuts **50a**. (Also, **50i** should be firmly tightened against **50a**).
- Insert upper valve assembly and screw into place by a few turns (**50e** or **50i** screws into **24** but should be loosened by one-half to one turn).
- If orifice **29** was removed, reinstall it.
- Inset lower valve assembly and screw into place by a few turns (**50h** screws into **50e**).
- Turn upper valve assembly so Allen screw **50g** is accessible through side inspection opening.
- Make the valve lock-up adjustment as follows:
  - Hold upper valve against its seat. This can be done by hand, reaching through side inspection opening.
  - While holding the upper valve against its seat, screw lower valve assembly upwards until the lower valve also touches its seat. When both upper and lower valves are touching their seats they are correctly adjusted for tight lock-up.
  - Firmly tighten Allen screw **50g**. This locks the adjustment by evenly and tightly locking **50h** and **50e** together.
 

**NOTE:** If the entire valve assembly was removed intact and Allen screw **50g** has not been loosened, the assembly may be reinstalled without making the lock-up adjustment.

- Screw entire valve assembly up (**50e** or **50i** screws into **24**) until it bottoms. Then **back off one-half to one full turn – this is important**.
- Replace side plates **38**.
- Replace bottom plate **33**. Match bottom end of **50h** into **31** and/or **32** and then turn bottom plate either way to first matching bolt hole position.

### To Remove Orifices

- Remove outlet orifice **29** per applicable steps 1 through 5 under section "To Remove Valves".
- Remove inlet orifice **28** as follows:
  - Remove seal cap **1**, back off adjusting screw **10**, remove housing cover **5** and spring **14**.
  - Remove bottom plate **33** and then unscrew valve assembly by grasping **50h** and turning (**50e** or **50i** unscrews from **24**).
  - Remove diaphragm case assembly by first opening union **60** and removing cap screws **34**.
  - Remove cap screws **26** and remove inlet orifice **28**. If orifice is tight, jack out cap screws in jacking holes. Use care with gasket **27**.
  - When replacing diaphragm assembly, the threaded connection between **24** and **50e** or **50i** should be screwed together until it bottoms and then **backed off one-half to one turn – this is important**.



**CAUTION**

Regulators are pressure control devices with numerous moving parts subject to wear that is dependent upon particular operating conditions. To ensure continuous satisfactory operation, adhere to a periodic inspection schedule with the frequency of inspection determined by the severity of service and applicable laws and regulations.

### To Change Spring

- Remove seal cap **1**, back off adjusting screw **10**, remove housing cover **5**, and remove spring **14**.
- Insert the new spring. Be sure it nests correctly onto part **15**.
- Complete as per steps 7, 8 and 9 under "To Assemble 441-S".

### To Service Diaphragm

- Remove seal cap **1**, back off adjusting screw **10**, remove housing cover **5**, and remove spring **14**.
- Remove bolts **42** and then carefully remove upper diaphragm case **43**.
- Turn diaphragm assembly counterclockwise until **24** unscrews from **50e** or **50i**, then remove assembly and inspect diaphragm.
- If a new diaphragm **20** is required, remove nut **16** and disassemble.
- Reassemble diaphragm assembly (parts **16**, **17**, **18**, **19**, **20**, **21**, **22**, **23**, **24**).
- Screw diaphragm assembly back into place (**24** screws into **50e** or **50i** until it bottoms) then **back off ½ to 1 full turn – this is important**.
- Carefully reinstall upper diaphragm case **43**. Diaphragm must not be pinched between upper and lower cases, **43** and **40**. Tighten bolts **42** evenly.
- Replace spring, etc., per steps 6 through 9 under "To Assemble 441-S".

### To Assemble 441-S

1. Install orifice **28** through top opening.
2. Install valve assembly and orifice **29** per applicable steps 1 through 6 under "To Replace and Adjust Valves" (except that **50e** or **50i** does not yet screw into **24**).
3. Install centerpiece and lower diaphragm case, **36** and **40**.
4. Install diaphragm assembly and upper case **43** per steps 5 through 7 under "To Service Diaphragm".
5. Replace bottom plate **33**. Match bottom end of **50h** into **31** and/or **32**, and then rotate bottom plate either way to first matching bolt hole position.
6. Insert the spring. Be sure it nests correctly onto part **15**.
7. Insert top spring button **12**. Be sure it is nested correctly on the spring.
8. Install housing cover **5**. Be sure ball **13** is in place and the lower end of adjusting screw **10** goes in the hole in button **12**.
9. Set adjusting screw **10** for desired outlet pressure, firmly tighten nut **11** and replace seal cap **1**.

### Over-pressurization Protection

Protection must be provided for the downstream piping system and the regulator's low pressure chambers to ensure against the potential over-pressurization due to a regulator malfunction or a failure of the regulator to lock-up. The allowable over-pressurization is the lowest of the maximum pressures permitted by federal codes, state codes, Bulletin RDS-1498, or other applicable standards. The method of providing over pressure protection could be a relief valve, a monitor regulator, a shut-off device or any similar device.

### Temperature Limits

The Model 441-S Regulator can be used for flowing temperatures from -20°F to 150°F.

### Buried Service

The Model 441-S Regulator is not recommended for buried service.

### Condensed Parts List

For complete parts list and list prices please refer to RP 1350. When ordering parts for a 441-S regulator, include pipe size, model number, inner valve size, and serial number if possible.

### Maximum Emergency Pressure

**NOTE:** Before using any of the following data, make sure this entire section is clearly understood.

The maximum pressure the Model 441-S regulator inlet may be subjected to under abnormal conditions without causing damage to the regulator is 125 psi.

The Maximum pressure the regulator outlet may be subjected to without causing damage to the internal part of the regulator is:

10" Diaphragm	set-point + 4 psi
12" Diaphragm	set-point + 3 psi
14" Diaphragm	set-point + 2 psi
16" Diaphragm	set-point + 1 psi
18" Diaphragm	set-point + 1 psi
20" Diaphragm	set-point + 1 psi

The set-point is defined as the outlet pressure a regulator is adjusted to deliver.

If any of the above pressure limits are exceeded, the regulator must be taken out of service and inspected. Damaged or otherwise unsatisfactory parts must be repaired or replaced.

The maximum pressure that can be safely contained by the diaphragm case is:

10" Diaphragm	15 psi
12" Diaphragm	10 psi
14" Diaphragm	10 psi
16" Diaphragm	5 psi
18" Diaphragm	5 psi
20" Diaphragm	5 psi

Safely contained means no leakage as well as no bursting.

### Other Gases

The Model 441-S is mainly used with natural gas services; however, this regulator will perform equally as well with other gases. When using the Model 441-S Regulator with other gases, the regulator capacities must be adjusted using the following correction factors.

Type of Gas	Correction Factor
Air (Specific Gravity 1.0)	0.77
Propane (Specific Gravity 1.53)	0.63
1350 BTU Propane-Air Mixture (Specific Gravity 1.20)	0.71
Nitrogen (Specific Gravity 0.97)	0.79
Dry Carbon Dioxide (Specific Gravity 1.52)	0.63

For other non-corrosive gases use the following formula:

$$\text{CORRECTION FACTOR} = \sqrt{\frac{0.60}{\text{Specific gravity of the gas}}}$$

For use with gases not listed above, please contact your Sensus Metering Systems representative or distributor for recommendations.

### All Models 441-S

Illustration Number	Description	Part Number
1a	Tetraseal (or O-Ring) 1 3/4" x 2"	904092
4	Hex Cap Screw, 5/16" - 18 x 3/4"	910028
6	Spring Cage Cover Gasket	090-16-066-30
7	Vent Cap, 1/4" NPT	137-02-505-02
9	Spring Cage Gasket	090-16-066-60
13	Thrust Bearing, 3/8" diameter stainless steel ball	930510
16	Hex Steel Nut, 5/8" - 18	905993
18	Seal Gasket, 2 used	014-76-179-03
20	7" Diaphragm	090-78-150-21
	10" Diaphragm	090-70-150-20
	12" Diaphragm	090-71-150-20
	14" Diaphragm	090-72-150-20
	16" Diaphragm	090-73-150-20
	18" Diaphragm	090-74-150-20
	20" Diaphragm	090-75-150-20

**All Models 441-S (Continued)**

Illustration Number	Description	Part Number
23	O-Ring, 1/16" I.D. 7/8" O.D.	934013
24	Diaphragm Connecting Stem, stainless steel	090-16-058-00
41	Hex Steel Nut, 3/8" – 16	920853
42	Hex Cap Screw, 3/8" – 16 x 1 1/8" Lg.	903568
45	Travel Indicator Assembly	

**2" Model 441-S**

Illustration Number	Description	Part Number
26	Hex Cap Screw, 1-4"-20 x 1/2" Lg., 120,000 tensile	910001
27	O-Ring, for Orifices	904832
28	1 1/4" Inlet Orifice, plated steel	090-16-028-00
	1 1/4" Inlet Orifice, stainless steel	090-16-028-50
	1 1/2" Inlet Orifice, plated steel	090-16-028-01
	1 1/2" Inlet Orifice, stainless steel	090-16-028-51
29	1 1/4" Outlet Orifice, plated steel	090-16-029-00
	1 1/4" Outlet Orifice, stainless steel	090-16-029-50
	1 1/2" Outlet Orifice, plated steel	090-16-029-01
	1 1/2" Outlet Orifice, stainless steel	090-16-029-51

**Monitoring**

The Model 441-S Regulator makes an excellent monitor. It can act as a standby regulator installed in series, which assumes control if a failure in the operating regulator permits the outlet pressure to exceed the set-point. It can be located in either the upstream or the downstream position.

When a Model 441-S Regulator is used to monitor a regulator with an identical inner valve (another 441 Regulator), the total maximum capacity through both regulators can be figured at 70% of the capacity of one regulator alone. This applies with the monitor located either up or downstream.

**3" Model 441-S**

Illustration Number	Description	Part Number
26	Hex Cap Screw, 1/4"-20 x 1/2" Lg., 120,000 tensile	910001
27	O-Ring, for Orifices	950818
28	2 1/8" Inlet Orifice, plated steel	090-20-028-00
	2 1/8" Inlet Orifice, stainless steel	090-20-028-50
	1 3/4" Inlet Orifice, plated steel	090-20-028-02
	1 3/4" Inlet Orifice, stainless steel	090-20-028-52
	1 1/2" Inlet Orifice, plated steel	090-20-028-03
	1 1/2" Inlet Orifice, stainless steel	090-20-028-53
29	2 1/8" Outlet Orifice, plated steel	090-20-029-00
	2 1/8" Outlet Orifice, stainless steel	090-20-029-50
	1 3/4" Outlet Orifice, plated steel	090-20-029-02
	1 3/4" Outlet Orifice, stainless steel	090-20-029-52
	1 1/2" Outlet Orifice, plated steel	090-20-029-03
	1 1/2" Outlet Orifice, stainless steel	090-20-029-53

**3" Model 441-S (Continued)**

Illustration Number	Description	Part Number
50	Valve Assembly, 2 1/4", brass trim, Buna-N (Black, 50-55 Duro)	090-20-515-30
	Valve Assembly, 2 1/4", stainless steel trim, Buna-N (Black, 50-55 Duro)	090-20-515-50
	Valve Assembly, 2 1/4", brass trim, Polyurethane (Red, 65-75 Duro)	090-20-515-40
50b	Valve Assembly, 2 1/4", stainless steel trim, Polyurethane (Red 65-75 Duro)	090-20-515-60
	Valve Retainer, standard, stainless steel, 2 1/8"	090-20-018-30
50d	Valve Retainer, v-port wings, stainless steel, 2 1/8"	090-20-012-51
	Molded Valve, 2 1/8", Buna-N (Black, 50-55 Duro) all trim	090-20-315-00
	Molded Valve, 2 1/8", Polyurethane (Red, 65-75 Duro) all trim	090-20-315-02

**2" and 3" Model 441-S**

Illustration Number	Description	Part Number
32	Guide Bushing with Pin, brass	090-16-385-01
	Guide Bushing with Pin, stainless steel	090-16-385-03
34	Hex Cap Screw, 1/2" – 13 x 1 1/4"	910106
35	Tetraseal (or O-Ring), 4 3/8" x 4 3/8"	904085
36a	Tetraseal, 4" x 4 1/4"	904084
37	Centerpiece, Stem Bushing	090-16-373-00
37a	Aluminum Seal Ring	090-26-178-00
39	Tetraseal (or O-Ring), 3 1/4" x 3 1/2"	904078
50	Valve Assembly, 1 3/4", brass trim, Buna-N (Black, 50-55 Duro)	090-16-515-27
	Valve Assembly, 1 3/4", stainless steel trim, Buna-N (Black, 50-55 Duro)	090-16-515-50
	Valve Assembly, 1 1/2", brass trim, Buna-N (Black, 50-55 Duro)	090-16-515-31
	Valve Assembly, 1 1/2", stainless steel trim, Buna-N (Black, 50-55 Duro)	090-16-515-51
50a	Valve Retaining Nut, 5/8" – 18	905564
50b	Valve Retainer, standard, steel, 1 1/4"	090-16-018-00
	Valve Retainer, standard, stainless steel, 1 1/4"	090-16-018-30
	Valve Retainer, v-port wings, stainless steel, 1 1/4"	090-16-012-53
	Valve Retainer, standard, steel, 1 1/2"	090-16-018-01
	Valve Retainer, standard, stainless steel, 1 1/2"	090-16-018-31
50c	Valve Retainer, v-port wings, steel, 1 1/2"	090-16-012-52
	Valve Retainer, v-port wings, stainless steel, 1 1/2"	090-16-012-55
50d	O-Ring, 5/8" x 1 3/16"	934012
50d	Molded Valve, 1 3/4", Buna-N (Black, 50-55 Duro) all trim	090-16-315-00
	Molded Valve, 1 1/2", Buna-N (Black, 50-55 Duro) all trim	090-16-315-01
	Molded Valve, 1 3/4", Polyurethane (Red, 65-75 Duro) all trim	090-16-315-02
	Molded Valve, 1 1/2", Polyurethane (Red, 65-75 Duro) all trim	090-16-315-03

**2" and 3" Model 441-S (Continued)**

Illustration Number	Description	Part Number
50e	Female Valve Stem, brass	090-16-116-00
	Female Valve Stem, stainless steel	090-16-116-01
50g	Adjustment Clamp Screw, Soc. Hd. Screw, 10-24 x 1/2" Lg.	903486
	Adjustment Clamp Screw, for 1 1/2" valve only	090-16-046-01
50h	Male Valve Stem, brass	090-16-016-01
	Male Valve Stem, stainless steel	090-16-016-02

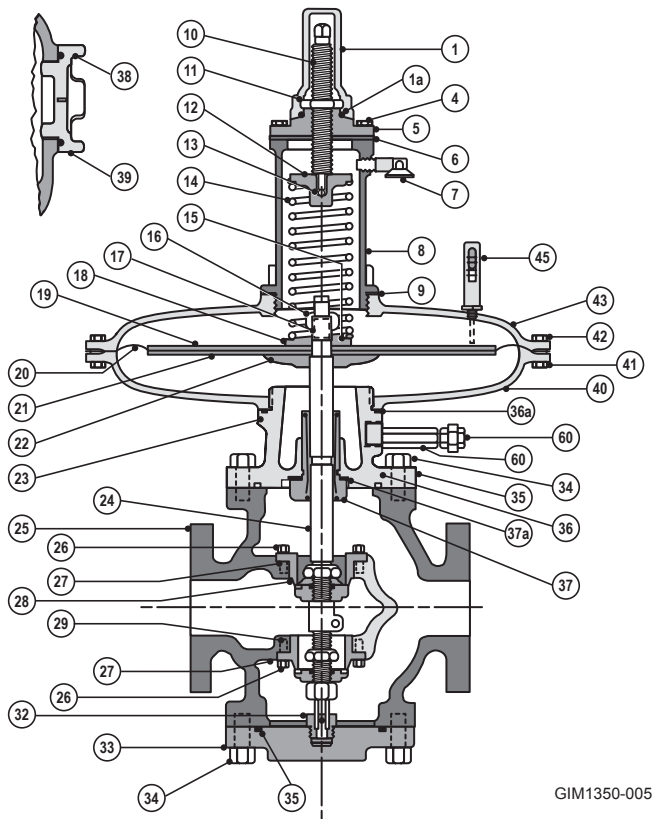

GIM1350-005

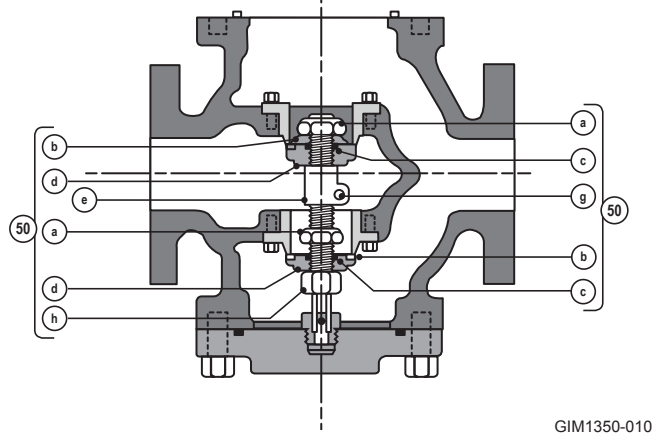

GIM1350-010

**2" AND 3" MODEL 441-S**

**4" Model 441-S**

Illustration Number	Description	Part Number
26	Hex Cap Screw, 3/8"-16 x 3/4" Lg., 120,000 tensile	910053
27	O-Ring, for orifices	905583
28	3" Inlet Orifice, plated steel	090-22-028-00
	3" Inlet Orifice, stainless steel	090-22-028-50
	2 1/2" Inlet Orifice, plated steel	090-22-028-02
	2 1/2" Inlet Orifice, stainless steel	090-22-028-52
	1 3/4" Inlet Orifice, plated steel	090-22-028-01
	1 3/4" Inlet Orifice, stainless steel	090-22-028-51
29	3" Outlet Orifice, plated steel	090-22-029-00
	3" Outlet Orifice, stainless steel	090-22-029-50
	2 1/2" Outlet Orifice, plated steel	090-22-029-02
	2 1/2" Outlet Orifice, stainless steel	090-22-029-52
	1 3/4" Outlet Orifice, plated steel	090-22-029-01
	1 3/4" Outlet Orifice, stainless steel	090-22-029-51
30	Hex Cap Screw, 3/8" - 16 x 1" Lg.	910055
31	Spin Stop Plate	090-22-040-01
32	Guide Bushing, brass	090-22-074-00
	Guide Bushing, stainless steel	090-22-074-01
34	Hex Cap Screw, 5/8" - 11 x 1 1/2"	910157
	Hex Cap Screw, 5/8" - 11 x 1 1/4" for ductile bottom plate	910158
35	Tetraseal (or O-Ring), 6 1/4" x 6 1/2"	904080
36a	Tetraseal (or O-Ring), 4" x 4 1/4"	904084
37	Centerpiece Stem Bushing	090-16-373-02
37a	Aluminum Seal Ring	090-26-178-00
39	Tetraseal (or O-Ring), 4-1/4" x 4-1/2"	904083
50	Valve Assembly, 3", brass trim, Buna-N (Black, 50-55 Duro)	090-22-515-30
	Valve Assembly, 3", stainless steel trim, Buna-N (Black, 50-55 Duro)	090-22-515-50
<i>Note: For other Valve Assemblies see RP 1350</i>		
50a	Valve Retaining Nut, 3/4" - 16	090-22-034-00
50b	Valve Retainer, standard, iron, 3"	090-22-018-03
	Valve Retainer, standard, stainless steel, 3"	090-22-018-00
	Valve Retainer, v-port wings, iron, 3"	090-22-012-20
	Valve Retainer, v-port wings, stainless steel, 3"	090-22-012-40
	Valve Retainer, standard, iron, 2 1/2"	090-22-018-01
	Valve Retainer, standard, stainless steel, 2 1/2"	090-22-018-31
	Valve Retainer, v-port wings, stainless steel, 2 1/2"	090-22-012-51
	Valve Retainer, standard, stainless steel, 1 3/4"	090-22-018-34
50c	O-Ring, 13/16" x 1"	904173
50d	Molded Valve, 3", Buna-N (Black, 50-55 Duro) all trim	090-22-315-00
	Molded Valve, 2 1/2", Buna-N (Black, 50-55 Duro) all trim	090-22-315-01
	Molded Valve, 1 3/4", Buna-N (Black, 50-55 Duro) all trim	090-22-315-04
	Molded Valve, 3", Polyurethane (Red, 65-75 Duro) all trim	090-22-315-02
	Molded Valve, 2 1/2", Polyurethane (Red, 65-75 Duro) all trim	090-22-315-03
	Molded Valve, 1 3/4", Polyurethane (Red, 65-75 Duro) all trim	090-22-315-05
50e	Female Valve Stem, brass	090-22-016-40
	Female Valve Stem, stainless steel	090-22-016-41
50f	Adjustment Clamp Ring, stainless steel	090-22-043-02

4" Model 441-S (Continued)

Illustration Number	Description	Part Number
50g	Adjustment Clamp Screw, Soc. Hd. Screw, 1/4" - 20 x 3/4" Lg.	903494
50h	Male Valve Stem, stainless steel	090-22-116-01
50i	Stem Extension, stainless, for 20" diaphragm only	090-22-058-40
50i	Stem Extension, stainless, for 18" and smaller diaphragms	090-22-058-41
52	Travel Stop, for 3" valves	090-22-040-51
52	Travel Stop, for 2 1/2" and 1 3/4" valves	090-22-040-55

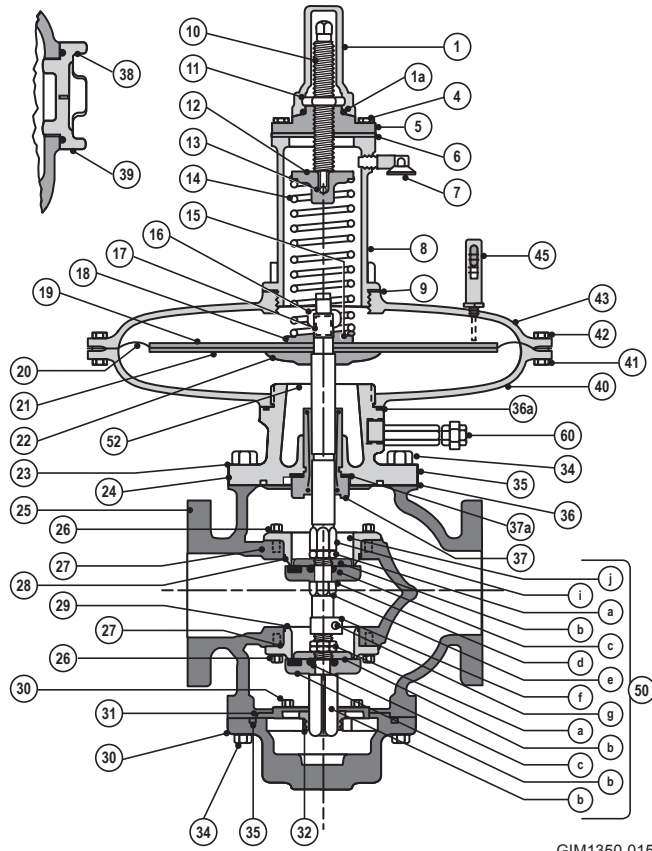

GIM1350-015

4" MODEL 441-S

Typical Arrangement And Dimensions (Indoor or Outdoor Installation)

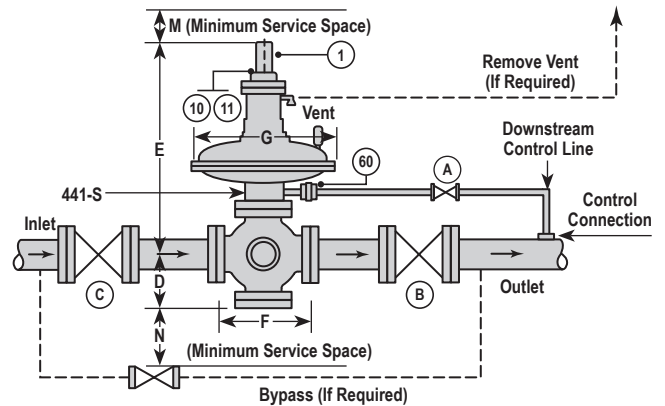

GIM1350-020

The 441-S should not be used for inlet exceeding 100 psig.

Regulator Body Type	F (Face to Face)		
	2" Pipe	3" Pipe	4" Pipe
Screwed	10"	—	—
Flanged ANSI 125	10"	11 1/4"	13 7/8"
Flanged ANSI 250	10 1/2"	12 1/2"	14 1/2"
Flanged ANSI 300	10 1/2"	12 1/2"	14 1/2"

Pipe Size of 441-S	D	E	G	M	N
2"	6"	24"	See Table Below	5"	7"
3"	6"	24"		5"	7"
4"	9 1/2"	26"		5"	8"

Springs are colored for identification. When shipped, the regulator is equipped with the lightest spring suitable for the maximum outlet pressure specified on order. If outlet pressure conditions change, replace spring accordingly to table below for best operation. For best performance use the largest diaphragm for the spring and pipe size selected.

For pressures below 4" w.c. install the Model 441-S upside down.

Outlet Pressure Ranges – Spring and Diaphragm Combinations

Spring Part Number	Spring Color	Diaphragm Size – Nominal Inside Diameter (Outside Diameter in Parenthesis, Dim. "G" above)					
		20"(23 1/8")	18"(20 5/8")	16"(18 5/8")	14"(16 3/8")	12"(14 3/4")	10"(13 1/8")
090-70-021-00	Aluminum	4 1/4" to 6" w.c.	4 1/4" to 4 3/4" w.c.	5 1/4" to 7" w.c.	7" to 10 1/2" w.c.	8 1/2" to 13" w.c.	
090-70-021-01	Green	4 3/4" to 7" w.c.	4 3/4" to 6 1/2" w.c.	7" to 10 1/2" w.c.	8 1/2" to 12" w.c.	10 1/2" to 17" w.c.	
090-70-021-02	Yellow	5 1/4" to 8 1/2" w.c.	6" to 10 1/2" w.c.	8 1/2" to 15 1/2" w.c.	10 1/2" to 17" w.c.	12" to 23" w.c.	
090-70-021-03	Gray	8 1/4" to 13" w.c.	10 1/2" to 17" w.c.	14" w.c. to 1 psi	17" w.c. to 1 1/4 psi	21" w.c. to 1 1/2 psi	1 1/4 to 2 psi
090-70-021-04	Blue	9 1/2" to 20" w.c.	16 1/2" to 21" w.c.	21" w.c. to 1 3/4 psi	21" w.c. to 2 psi	1 1/4 to 2 1/2 psi	1 1/2 to 3 1/4 psi
090-70-021-05	Red				1 1/2 to 3 3/4 psi	1 3/4 to 4 psi	2 1/2 to 6 psi

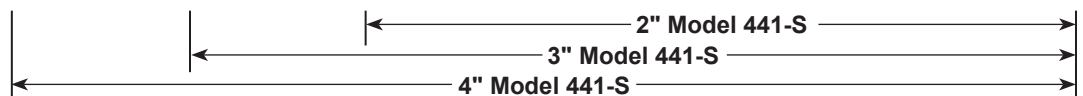



# Model 441-S Regulator

Installation and Maintenance Instructions



## Authorized Distributor:

All products purchased and services performed are subject to Sensus terms of sale, available at either: <http://na.sensus.com/TC/TermsConditions.pdf> or 1-800-METER-IT. Sensus reserves the right to modify these terms and conditions in its own discretion without notice to the customer.

This document is for informational purposes only, and SENSUS MAKES NO EXPRESS WARRANTIES IN THIS DOCUMENT. FURTHERMORE, THERE ARE NO IMPLIED WARRANTIES, INCLUDING WITHOUT LIMITATION, WARRANTIES AS TO FITNESS FOR A PARTICULAR PURPOSE AND MERCHANTABILITY. ANY USE OF THE PRODUCTS NOT SPECIFICALLY PERMITTED HEREIN IS PROHIBITED.