



INSTALLATION, OPERATION, AND MAINTENANCE MANUAL
WELKER PORTABLE ODORIZER
WITH XL4 CONTROLLER



MODEL
POC

DRAWING NUMBERS
OE143SYS.1
OE143SYS.3
OE143SYS.5

MANUAL NUMBER
IOM-219

REVISION
Rev. A, 05/15/2018

TABLE OF CONTENTS

	SAFETY	3
1.	PRODUCT INFORMATION	4
1.1	Introduction	4
1.2	Product Description	4
1.3	Safety Warning	4
1.4	Specifications	5
1.5	Equipment Diagrams	6
2.	INSTALLATION & OPERATION	11
2.1	Before You Begin	11
2.2	Installation	11
2.3	Start-Up Procedures	15
2.4	Decommissioning Procedures	18
3.	XL4 TOUCH SCREEN CONTROLLER	19
3.1	Understanding the Display	19
3.2	Navigating the Monitor Menus	22
3.3	Navigating the Setup Menus	30
4.	MAINTENANCE	55
4.1	Before You Begin	55
4.2	Maintenance	55
4.3	Troubleshooting	56
	APPENDICES	57
	A: Referenced or Attached Documents	57
	B: Maintenance Schedule	58

IMPORTANT SAFETY INFORMATION

READ ALL INSTRUCTIONS



Notes emphasize information and/or provide additional information to assist the user.



Caution messages appear before procedures that could result in damage to equipment if not observed.



Warning messages appear before procedures that could result in personal injury if not observed.

This manual is intended to be used as a basic installation and operation guide for the Welker OdorEyes Portable Odorizer, POC. For comprehensive instructions, please refer to the IOM Manuals for each individual component. A list of relevant component IOM Manuals is provided in Appendix A of this manual.

The information in this manual has been carefully checked for accuracy and is intended to be used as a guide for the installation, operation, and maintenance of the Welker OdorEyes equipment described in this manual. Correct installation and operation, however, are the responsibility of the end user. Welker reserves the right to make changes to this manual and all products in order to improve performance and reliability.

BEFORE YOU BEGIN

Read these instructions completely and carefully.

IMPORTANT – Save these instructions for local inspector's use.

IMPORTANT – Observe all governing codes and ordinances.

Note to Installer – Leave these instructions with the end user.

Note to End User – Keep these instructions for future reference.

Installation of this Portable Odorizer is of a mechanical and electrical nature.

Proper installation is the responsibility of the installer. Product failure due to improper installation is not covered under the warranty.

If you received a damaged Portable Odorizer, please contact a Welker representative immediately.

Phone: 281.491.2331

Address: 13839 West Bellfort Street
Sugar Land, TX 77498

1.1 Introduction

We appreciate your business and your choice of Welker products. The installation, operation, and maintenance liability for this equipment becomes that of the purchaser at the time of receipt. Reading the applicable *Installation, Operation, and Maintenance (IOM) Manuals* prior to installation and operation of this equipment is required for a full understanding of its application and performance prior to use.*

If you have any questions, please call Welker at 1-281-491-2331.

**The following procedures have been written for use with standard Welker OdorEyes parts and equipment. Assemblies that have been modified may have additional requirements and specifications that are not listed in this manual.*

1.2 Product Description

The Welker OdorEyes POC Portable Odorizer is a portable odorant injection system designed to inject liquid odorant proportional to time into a natural gas pipeline.

The pump cabinet contains one (1) Welker OdorEyes BIP Bellows Injection Pump, which injects the liquid odorant into the pipeline. To prolong the operational life of the injection pump, an inline filter removes particles from the liquid odorant and the Welker F-19 Filter Dryer conditions the pneumatic supply.

The POC is designed for pneumatic operation. The pneumatic timer strokes the pump, and the optional pneumatic counter tallies each stroke. For added automation and to enable proportional to flow injection, the POC can be equipped with the optional touch screen controller. The touch screen controller serves as the system's brain. It continuously receives feedback from the customer's gas flow meter and the odorant flow meter in the pump cabinet, allowing the system to respond to changing flow conditions. As pipeline conditions change, the controller increases or decreases the injection rate so that the POC continues injection proportional to flow. On-site and remote troubleshooting are made easier by time- and date-stamped audit data detailing system performance, alarm history, and odorant tank level. For automated POCs used in remote locations, a solar panel with battery can be added to limit interruptions to operation.

Welker may custom design the POC to suit the particular application and specifications of each customer.

1.3 Safety Warning

Wherever hazardous gases or vapor-producing liquids are used, transported, or stored, the potential for an accidental leak exists. Continuous monitoring of these hazards is essential to ensure personnel safety.

1.4 Specifications



The specifications listed in this section are generalized for this equipment. Welker can modify the equipment according to your company's needs. **Please note that the specifications may vary depending on the customization of your equipment.**

Table 1: POC Specifications

Application	Liquid Odorant Injection
Maximum Allowable Operating Pressure	2000 psig @ -20 °F to 120 °F (137 barg @ -28 °C to 48 °C)
Utility Requirements	Pneumatic Supply: For Pump Operation Pneumatic Supply: For Blanket Pressure
Electrical Connections	Controller (Optional): DC 12 V Solar Panel (Optional): DC 12 V Solenoid (Optional): DC12 V
Injection Volume	BIP-1: 0.5–3 cc BIP-2: 0.1–0.75 cc BIP-3: 1–9 cc
Operation	BIP: Piston-Operated
Mounting	On 2-Wheel Hand Truck
Features	Flexlines With Quick-Connects Inline Odorant Filter Mounting Bracket for Customer-Supplied 5-Gallon Odorant Supply Tank NEMA 4 Enclosure Outlet Check Valve Pneumatic Timer Regulator for Blanket Pressure Regulator for Pneumatic Supply Welker OdorEyes BIP-1, BIP-2, or BIP-3 Bellows Injection Pump Welker F-19 Filter Dryer
Electrical Area Classification	NEC Class I, Div. 1
Options	3-Way Solenoid Valve Flow Meter With Bypass Pneumatic Counter Purge Valve Solar Panel Mounted on Second 2-Wheel Hand Truck Touch Screen Controller With NEMA 4X Enclosure Welker SG-4 Sight Glass

1.5 Equipment Diagrams

Figure 1: General Arrangement – POC Hand Truck

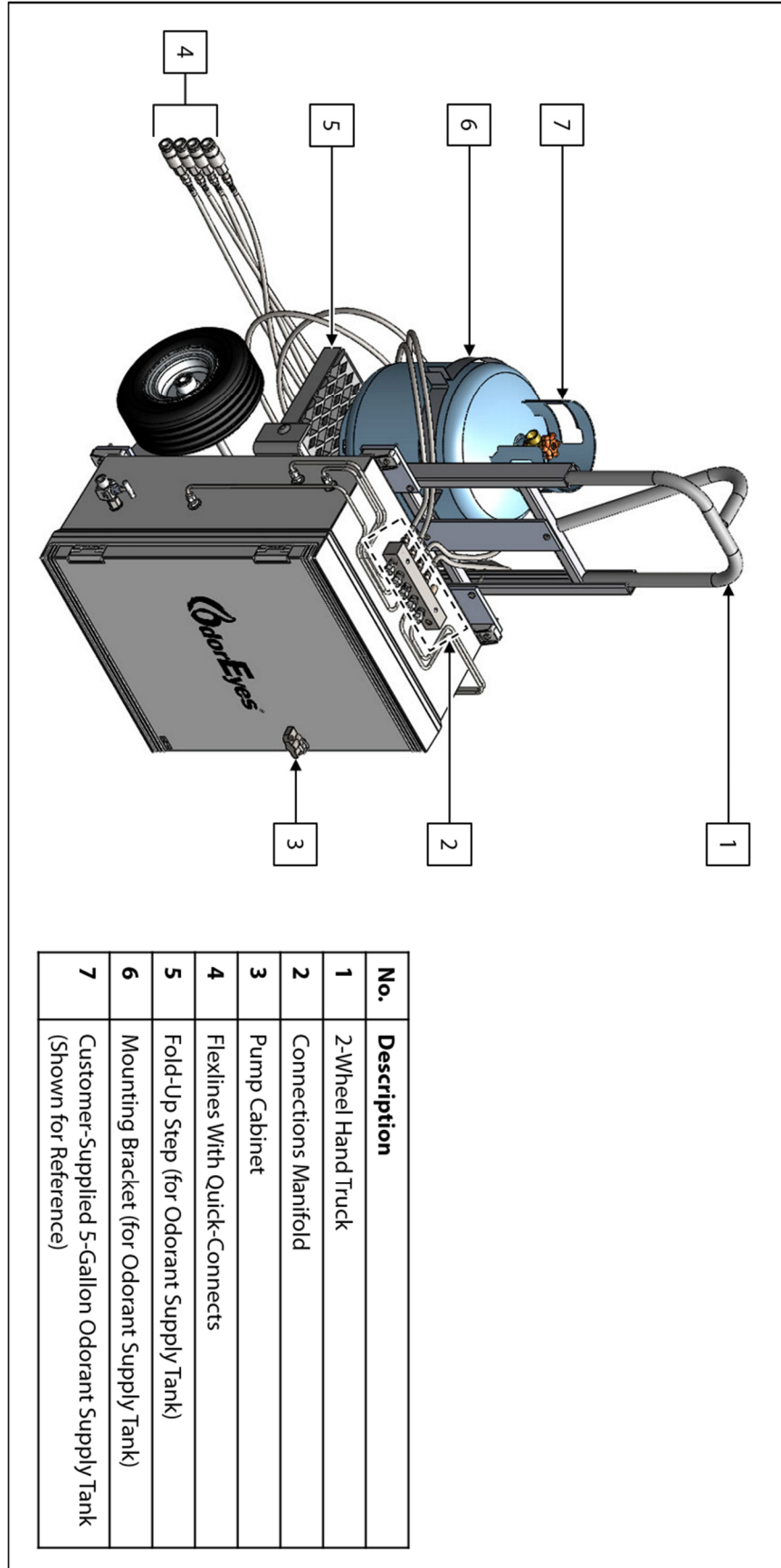

Figure 2: General Arrangement – Solar Panel Hand Truck (Optional)

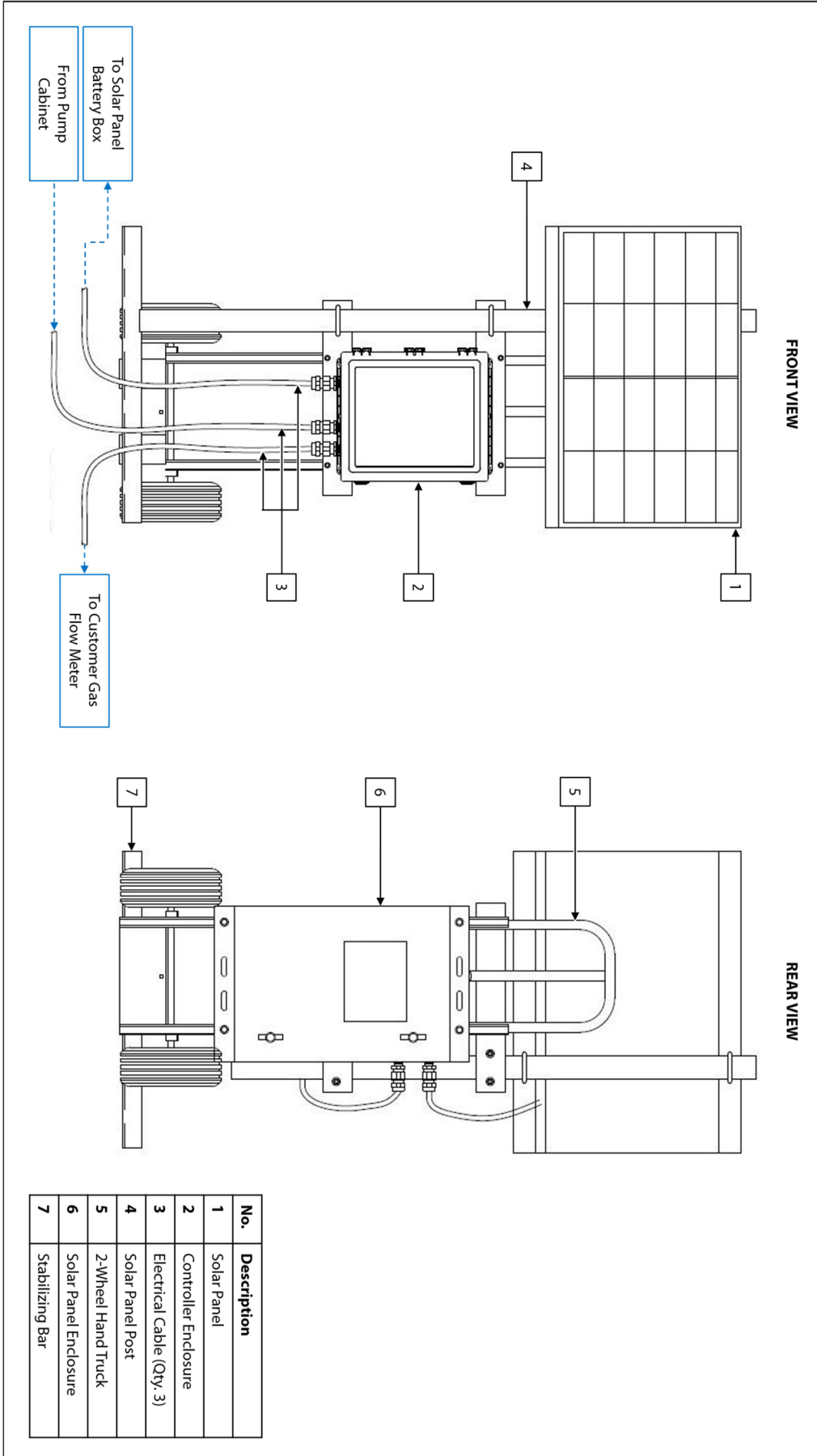

Figure 3: Standard POC Pump Cabinet

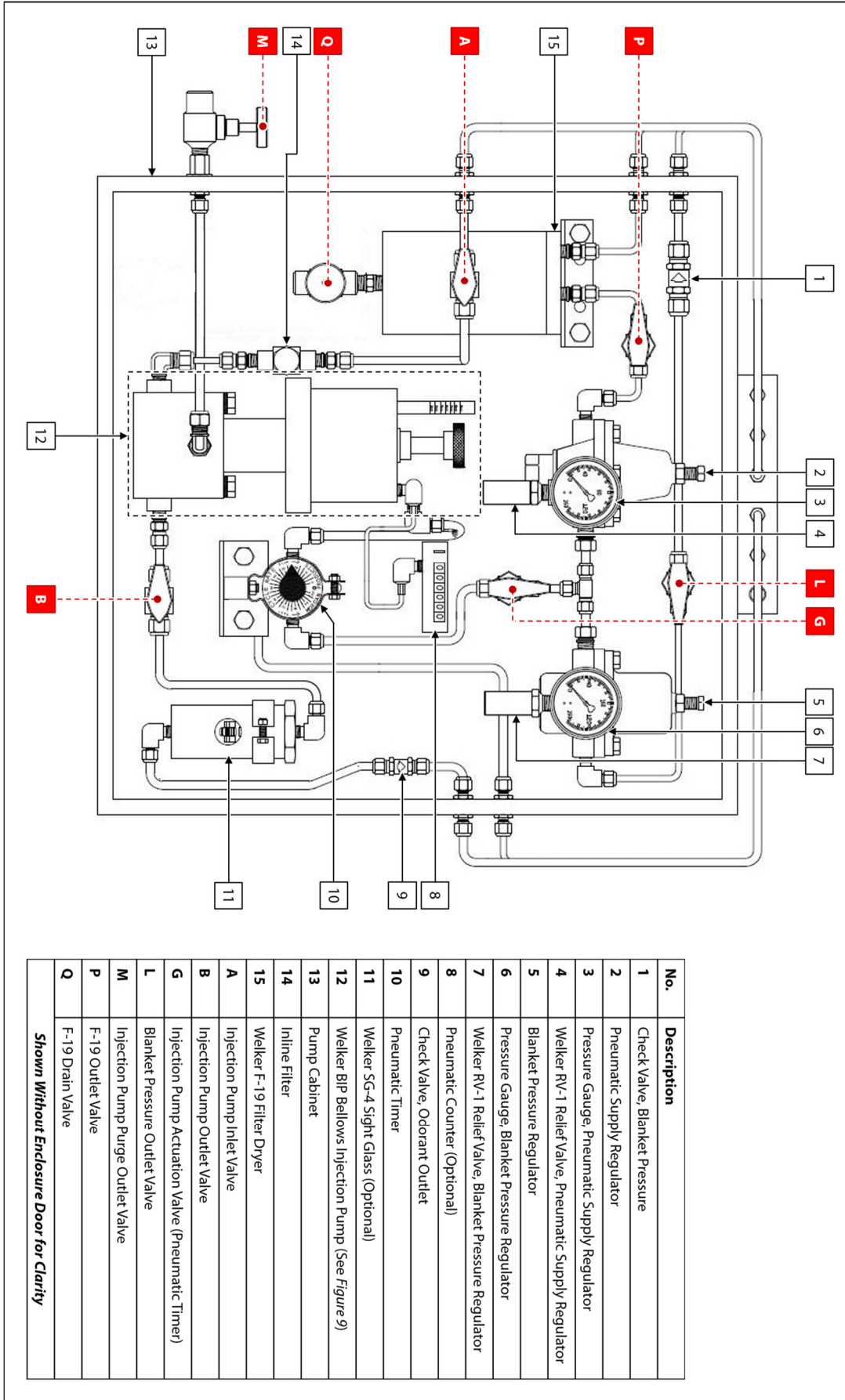
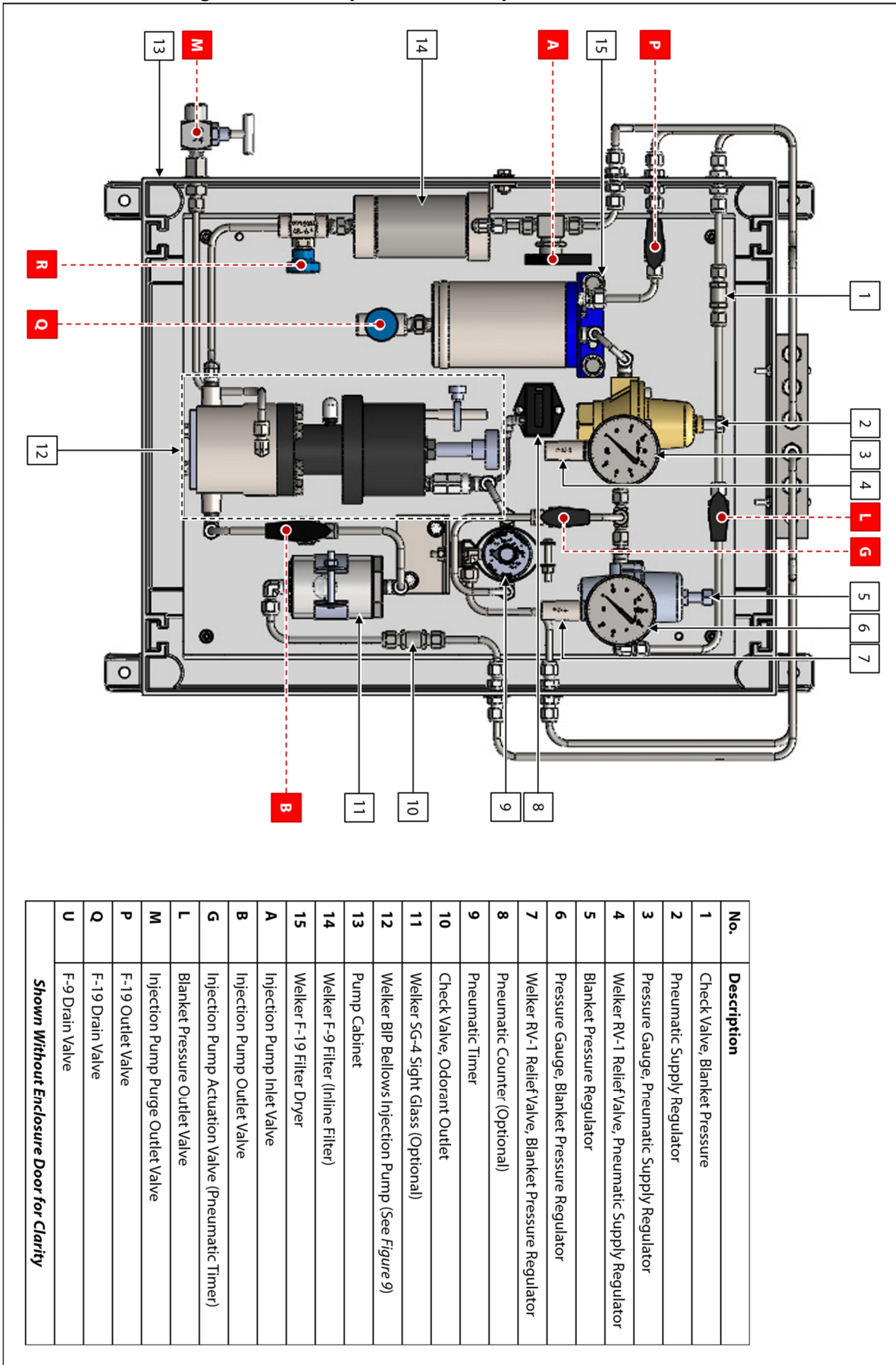

Figure 4: POC Pump Cabinet With Optional Welker F-9 Filter



No.	Description
1	Check Valve, Blanket Pressure
2	Pneumatic Supply Regulator
3	Pressure Gauge, Pneumatic Supply Regulator
4	Welker RV-1 Relief Valve, Pneumatic Supply Regulator
5	Blanket Pressure Regulator
6	Pressure Gauge, Blanket Pressure Regulator
7	Welker RV-1 Relief Valve, Blanket Pressure Regulator
8	Pneumatic Counter (Optional)
9	Pneumatic Timer
10	Check Valve, Odorant Outlet
11	Welker SG-4 Sight Glass (Optional)
12	Welker BIP Bellows Injection Pump (See Figure 9)
13	Pump Cabinet
14	Welker F-9 Filter (Inline Filter)
15	Welker F-19 Filter Dryer
A	Injection Pump Inlet Valve
B	Injection Pump Outlet Valve
G	Injection Pump Actuation Valve (Pneumatic Timer)
L	Blanket Pressure Outlet Valve
M	Injection Pump Purge Outlet Valve
P	F-19 Outlet Valve
Q	F-19 Drain Valve
U	F-9 Drain Valve

Shown Without Enclosure Door for Clarity

Figure 5: POC Pump Cabinet With Optional Solenoid and Flow Meter

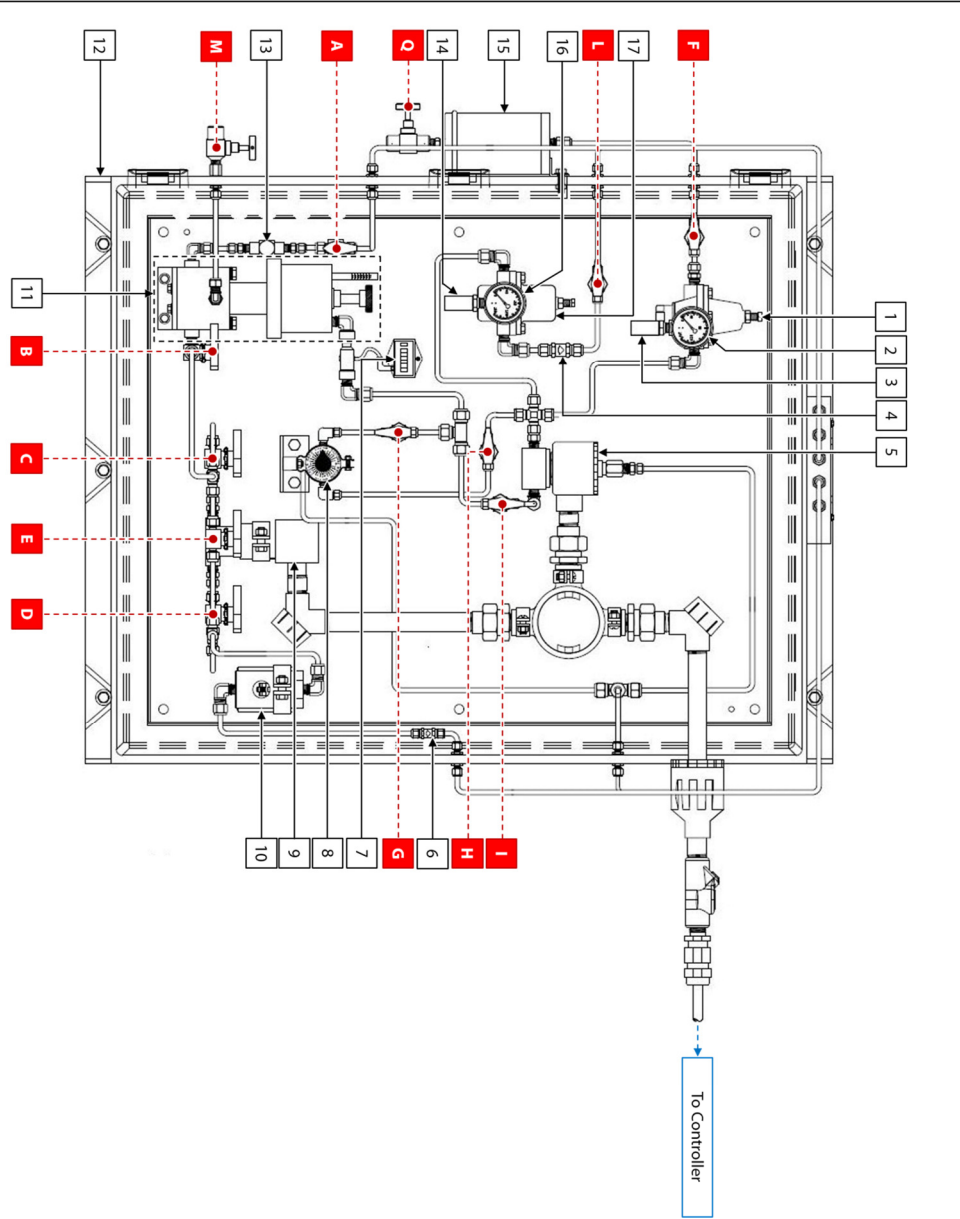

No.	Description
1	Pneumatic Supply Regulator
2	Pressure Gauge, Pneumatic Supply Regulator
3	Welker RV-1 Relief Valve, Pneumatic Supply Regulator
4	Check Valve, Blanket Pressure
5	Solenoid (Optional)
6	Check Valve, Odorant Outlet
7	Pneumatic Counter (Optional)
8	Pneumatic Timer
9	Flow Meter (Optional)
10	Welker SG-4 Sight Glass (Optional)
11	Welker BIP Bellows Injection Pump (See Figure 9)
12	Pump Cabinet
13	Inline Filter
14	Welker RV-1 Relief Valve, Blanket Pressure Regulator
15	Welker F-19 Filter Dryer
16	Pressure Gauge, Blanket Pressure Regulator
17	Blanket Pressure Regulator
A	Injection Pump Inlet Valve
B	Injection Pump Outlet Valve
C	Odorant Flow Meter Inlet Valve
D	Odorant Flow Meter Outlet Valve
E	Odorant Flow Meter Bypass Valve
F	Pneumatic Supply Inlet Valve
G	Injection Pump Actuation Valve (Pneumatic Timer)
H	Pneumatic Timer Isolation Valve
I	Injection Pump Actuation Valve (Normal Operation)
L	Blanket Pressure Outlet Valve
M	Injection Pump Purge Outlet Valve
Q	F-19 Drain Valve

Shown Without Enclosure Door for Clarity

SECTION 2: INSTALLATION & OPERATION

2.1 Before You Begin



After unpacking the unit, check the equipment for compliance and any damage that may have occurred during shipment. Immediately contact a Welker representative if you received damaged equipment.



When sealing fittings with PTFE tape, refer to the proper sealing instructions for the brand used.



The POC Portable Odorizer will ship mounted on a two-wheel hand truck and “hard-tube” connected with manufacturer-supplied fittings and hardware. However, the customer may need to supply some tubing and fittings in order to complete the installation of the system.

2.2 Installation

Hand Trucks

1. Locate the POC hand truck as close to the injection point as possible.
2. If the POC is equipped with the optional solar panel and touch screen controller on a second hand truck, locate this hand truck as close to the POC hand truck as possible, taking shading and direction of the sun into account.



Ensure that the solar panel battery has been removed from the solar panel enclosure prior to moving the hand truck.



The distance between the two (2) hand trucks is limited by the length of the provided electrical cables.



The solar panel must face the direction of the sun and cannot be shaded during daylight hours. Any shading of the solar panel could greatly reduce the output of the solar panel and inhibit the battery from charging.

Odorant Supply Tank



Odorant must be transported in a DOT certified container.

3. Fill the customer-supplied odorant supply tank in accordance with company policy and procedure, taking care not to exceed 80% of the total volume of the supply tank.



Never fill the odorant supply tank above 80% of its capacity. Allow at least 20% for product expansion, should the tank be exposed to increased temperatures.

4. With the fold-up step on the POC hand truck in the down position, install the filled odorant supply tank to the hand truck (*Figure 1*).
5. Using the mounting bracket, secure the filled odorant supply tank to the POC hand truck (*Figure 1*).

System Connections



For ease of mobility, the POC is equipped with flexlines with quick-connects for system connections. However, stainless steel tubing may be used in more permanent applications.



Welker recommends using stainless steel tubing for all natural gas process lines, as plastic tubing can absorb odorant from the gas.

Figure 6: Pump Cabinet Connections Diagram

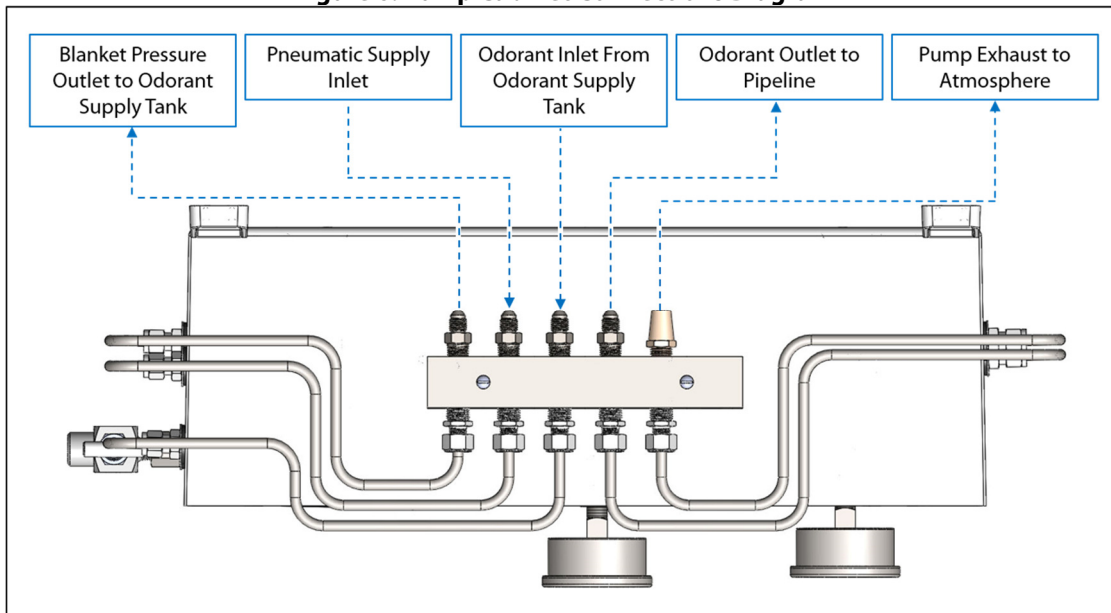
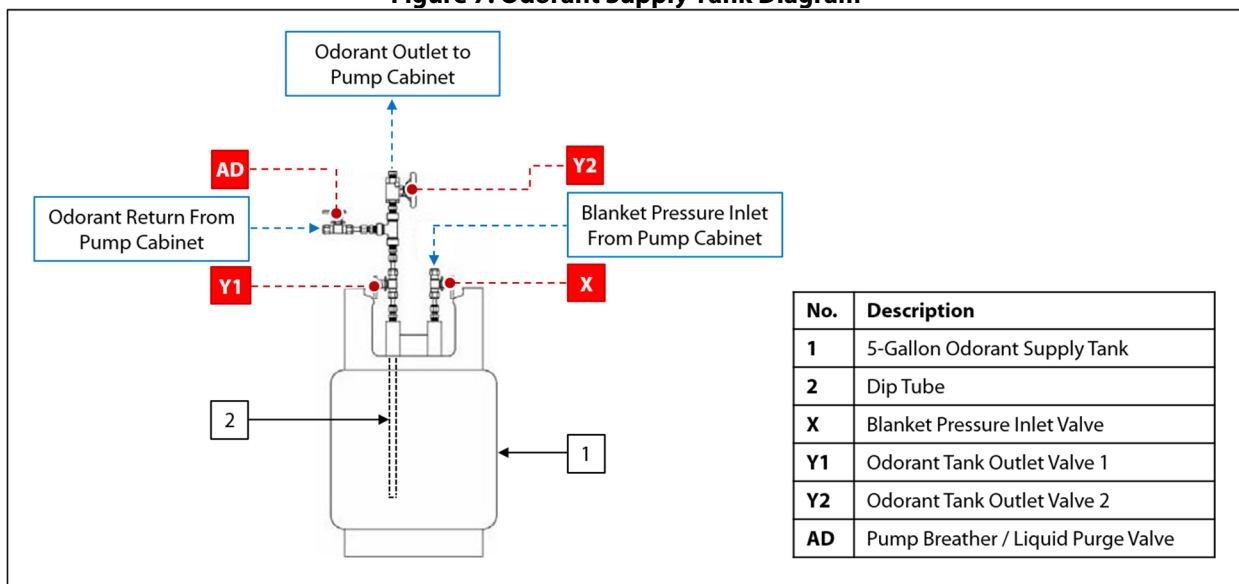

Figure 7: Odorant Supply Tank Diagram



6. Using a provided flexline with quick-connects, connect from the blanket pressure outlet on the pump cabinet to the blanket pressure inlet on the odorant supply tank. The quick-connects will click audibly into place.
7. Using a provided flexline with quick-connects, connect from the odorant outlet on the odorant supply tank to the odorant inlet on the pump cabinet. The quick-connects will click audibly into place.
8. Using a provided flexline with quick-connects, connect from the customer-supplied unodorized natural gas or inert gas supply to the pneumatic supply inlet on the pump cabinet. The quick-connects will click audibly into place.
9. Using the longest provided flexline with quick-connects, connect from the odorant outlet on the pump cabinet to the customer pipeline injection point.



Welker recommends installing a valve between the system odorant outlet and the injection point.

10. Ensure that all valves on the system are closed.
11. Ensure that all fittings and connections are tightened.
12. If the POC is equipped with the optional solar panel, continue to step 13. If the POC is not equipped with the optional solar panel, proceed to *Section 2.3, Start-Up Procedures*.

Solar Panel Connections



Follow the appropriate electrical zone regulations and guidelines. DO NOT place NEC Class I, Div. 2 electrical components in NEC Class I, Div. 1 zones.



For systems used in hazardous locations, sealing compound is required to seal all fittings to restrict the passage of gases, vapors, or flames.

13. Install the optional solar panel to the top of the solar panel post on the controller hand truck (*Figure 2*).



The solar panel must face the direction of the sun and cannot be shaded during daylight hours. Any shading of the solar panel could greatly reduce the output of the solar panel and inhibit the battery from charging.

Figure 8: Electrical Connections Configuration and Wiring Diagram

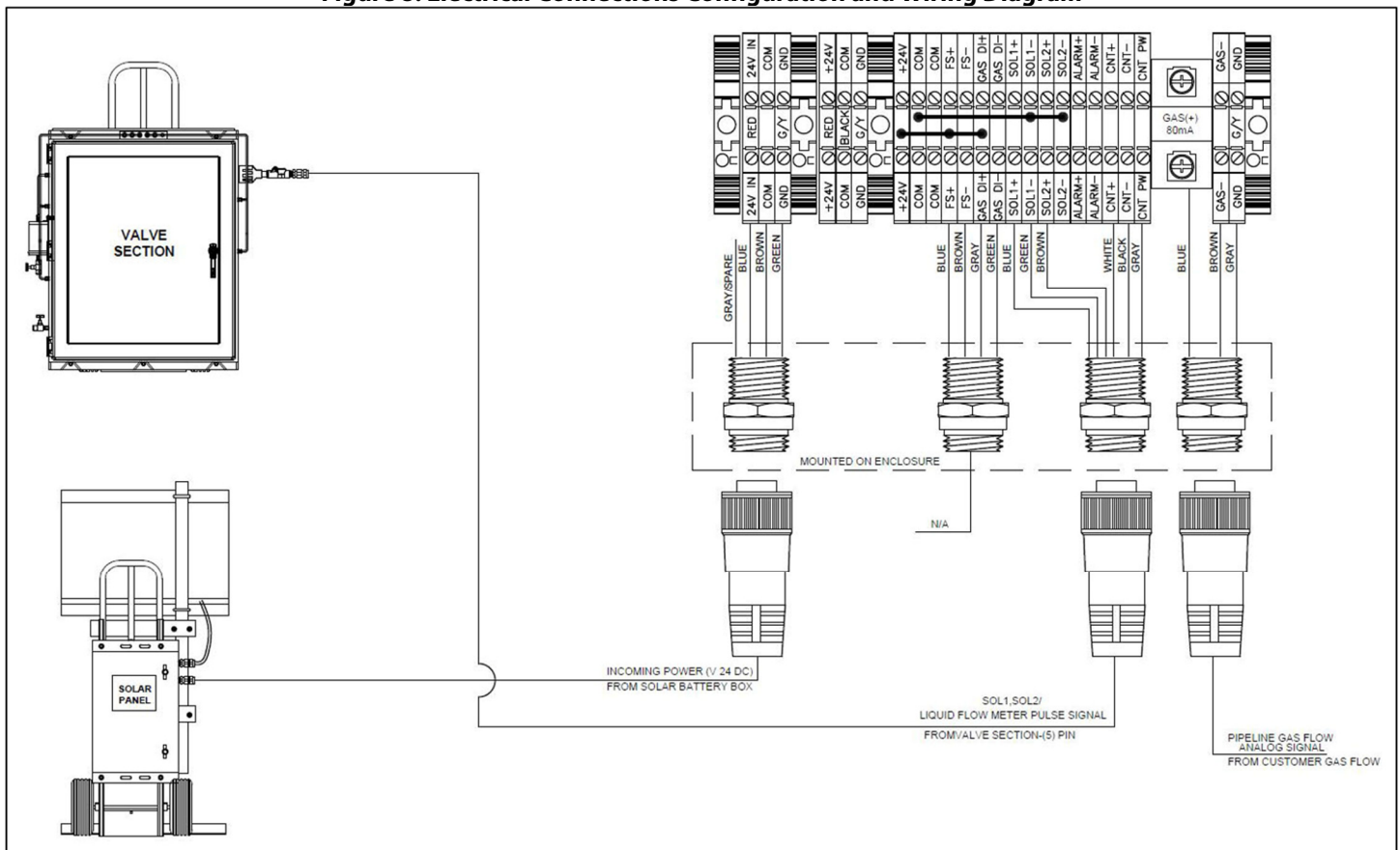

14. Install the solar panel battery to the solar panel enclosure on the second hand truck, and then connect the solar panel to the battery.
15. Using a provided electrical cable, connect from the pump cabinet to the controller enclosure (*Figure 2*).
16. Using a provided electrical cable, connect from the controller enclosure to the customer gas flow meter (*Figure 2*).



The controller can accept analog input.

2.3 Start-Up Procedures

Pneumatic Supply Regulator

1. If the POC is equipped with the standard pump cabinet, open F-19 outlet valve P (*Figure 3*).
2. If the POC is equipped with the pump cabinet with optional solenoid and flow meter, open pneumatic supply inlet valve F (*Figure 5*).
3. Apply pneumatic supply pressure to the pump cabinet. The pneumatic supply regulator will be pressurized.
4. Set the pneumatic supply regulator according to the recommended settings in Table 2 to the pressure required to stroke the pump located inside the pump cabinet.

Table 2: Injection Pump Pressure Regulator Settings

Injection Pressure	Approximate Regulator Set Point
0–400 psig	30 psig
401–800 psig	50 psig
801–1200 psig	80 psig
1201–2000 psig	100 psig

Blanket Pressure

5. Open blanket pressure inlet valve X (*Figure 7*).
6. Open blanket pressure outlet valve L (*Figure 3, Figure 4, or Figure 5*).
7. Check the blanket pressure connections for leaks and repair as necessary.

Valve Configuration

8. Slowly open the valves indicated in Table 3.

Table 3: Start-Up Valve Orientation

Valve Letter	Valve Description	Reference Figure(s)
Y (Y1 and Y2)	Odorant Outlet	7
A	Injection Pump Inlet	3, 4, 5
B	Injection Pump Outlet	3, 4, 5
E	Odorant Flow Meter Bypass	5

9. Slowly open any valves between the odorant outlet on the pump cabinet and the pipeline.
10. Check for leaks and repair as necessary.

Purging the Injection Pump

11. Open injection pump purge outlet valve M to purge the injection chamber of any trapped air (Figure 3, Figure 4, or Figure 5).
12. Once all air has been purged from the injection chamber, close injection pump purge outlet valve M (Figure 3, Figure 4, or Figure 5).
13. As necessary, adjust the injection volume of the injection pump.



Loosen the jam nut on the adjustment screw.

To increase the injection volume, turn the adjustment knob counterclockwise.

To decrease the injection volume, turn the adjustment knob clockwise.

Tighten the jam nut on the adjusting screw to secure the adjusting screw at the desired volume.

Figure 9: BIP Diagram

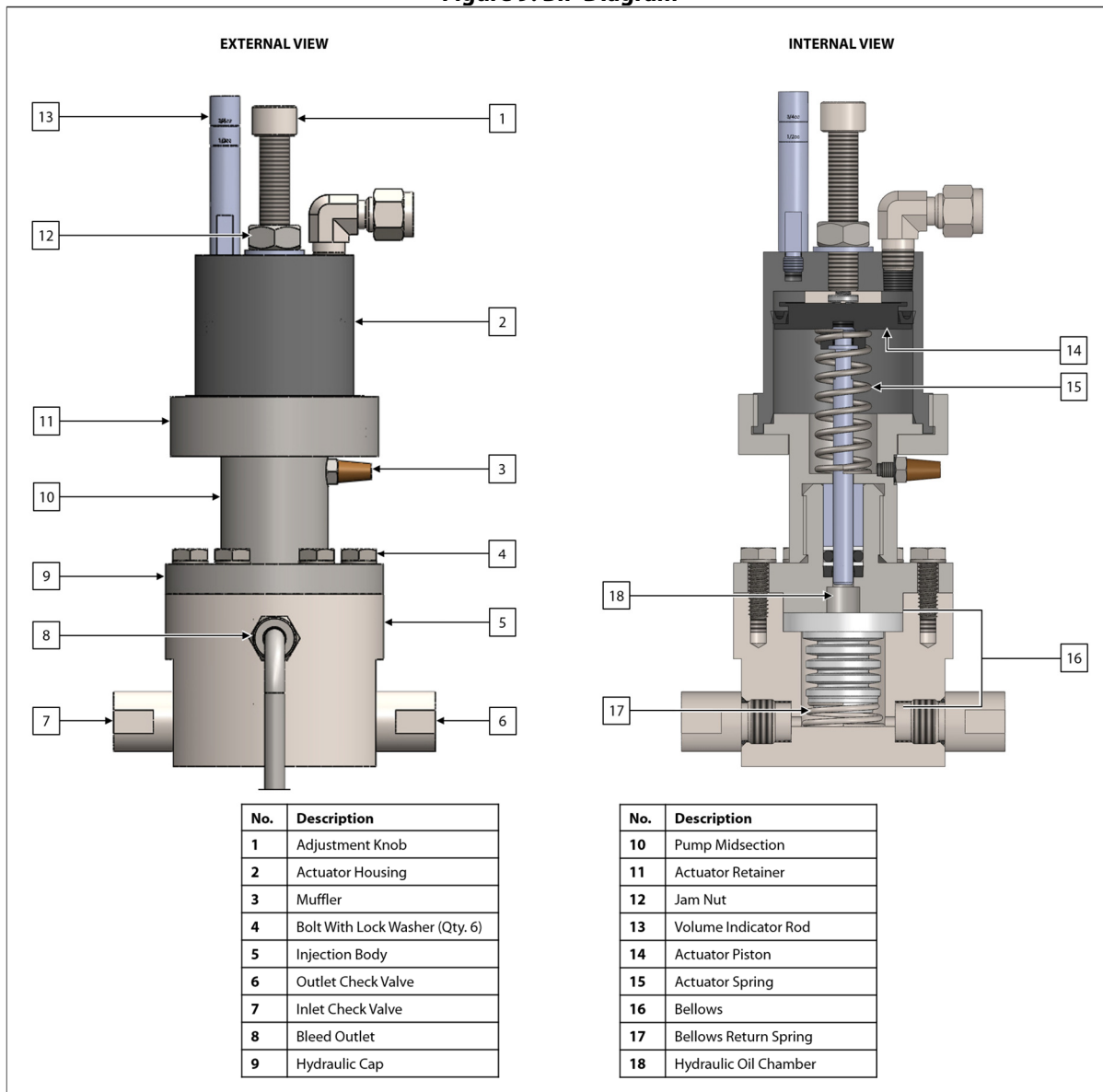

14. If applicable, **slowly** open flow meter outlet valve D and flow meter inlet valve C, and then close flow meter bypass valve E (Figure 5).
15. Open any valve(s) restricting the flow of odorant from the POC to the pipeline.

Verifying Pump Operation



If the POC is equipped with the optional controller, Welker recommends turning OFF the controller prior to verifying pump operation using the pneumatic timer.

16. Open injection pump actuation valve G (*Figure 3, Figure 4, or Figure 5*).
17. If applicable, open injection pump isolation valve H (*Figure 5*).
18. If applicable, close injection pump actuation valve I (*Figure 5*).
19. Turn the dial on the front of the pneumatic timer to set the stroke frequency of the injection pump.



To get a full stroke of the injection pump, do not set the stroke frequency faster than every six (6) seconds.

20. As the injection pump strokes, verify liquid odorant is being injection into the pipeline by referring to the Welker SG-4 Sight Glass. The Visual Flow Indicator (a.k.a. Spinner Wheel) inside the SG-4 should spin.



Welker recommends a minimum of ten (10) actuations to verify injection.

21. If the POC is not equipped with the optional controller, the POC is operational once the injection of liquid odorant has been verified. If the POC is equipped with the optional controller, continue to step 22.

Controller Configuration

22. Close injection pump actuation valve G and injection pump isolation valve H, and then open injection pump isolation valve I (*Figure 5*). This stops the flow of the pneumatic supply to the pneumatic timer, allowing the controller and solenoid to stroke the injection pump.
23. Verify that the customer set points have been correctly set by the manufacturer.
24. The POC is now operational.

2.4 Decommissioning Procedures



The system should be decommissioned prior to transport to another location.



Welker recommends having OdorXice Plus™ during decommissioning to control the odorant smell.

1. If the pneumatic timer is being used to stroke the injection pump, close injection pump actuation valve G (*Figure 3, Figure 4, or Figure 5*).



DO NOT close injection pump actuation valve I during a pump stroke. Wait until the pump completes the stroke before closing the valve.

2. If the optional controller is being used to stroke the injection pump, close injection pump actuation valve I (*Figure 5*).



DO NOT close injection pump actuation valve G during a pump stroke. Wait until the pump completes the stroke before closing the valve.

3. Close any valves between the odorant outlet on the pump cabinet and the pipeline.
4. Close blanket pressure inlet valve X and odorant tank outlet valve Y2 on the customer-supplied odorant supply tank (*Figure 7*).
5. Disconnect the flexline with quick-connects from the pipeline injection point, and then connect the flexline to pump breather / liquid purge valve AD on the customer-supplied odorant supply tank (*Figure 7*).
6. If a valve was installed to the outlet of the flexline with quick-connects, open this valve.
7. Open pump breather / liquid purge valve AD.
8. Once the pump cabinet has been purged, close pump breather / liquid purge valve AD and the valve on the outlet of the flexline with quick-connects, if applicable.
9. Disconnect the flexline with quick-connects from pump breather / liquid purge valve AD.
10. Disconnect the blanket pressure flexline with quick-connects from blanket pressure inlet valve X on the customer-supplied odorant supply tank (*Figure 6*).
11. Disconnect the pneumatic supply flexline with quick-connects from the customer-supplied unodorized natural gas or inert gas supply (*Figure 6*).
12. Disconnect the odorant supply flexline with quick-connects from odorant tank outlet valve Y2 on the customer-supplied odorant supply tank (*Figure 6*).
13. If the POC is equipped with the optional solar panel, disconnect the battery from the solar panel, and then remove the solar panel battery from the solar panel enclosure on the second hand truck.



The solar panel battery must be removed from the solar panel enclosure prior to moving the hand truck.

14. The POC may now be cleaned and prepared for transport to another location.

3.1 Understanding the Display



The touch screen controller is used to modify system parameters and view current system information and current alarm status.



The touch screen controller is a menu-driven system. The Home screen is the top screen in the menu tree (Figure 10).

Figure 10: Home Screen





	<p>Monitor Takes you to the monitoring screens where you can view current information about the operation of the odorizer.</p>		<p>Setup Takes you to the setup screens where you can change any set point values in the odorizer.</p>
--	---	--	---

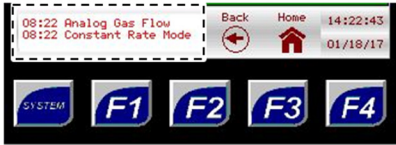
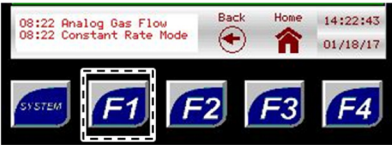
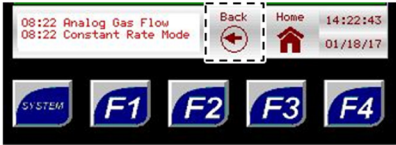

From the Home screen, the user can access three (3) types of screens:

- **Menu**-from this type of screen, the user can access submenus.
- **Informational**-from this type of screen, the user can monitor the odorizer and view current operating conditions.
- **Setup**-from this type of screen, numeric and/or text values that affect the setup of the odorizer can be changed.

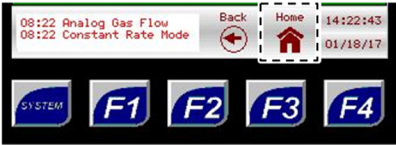
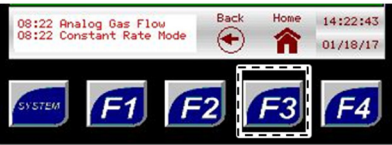
Figure 11: Toolbar and Function Keys

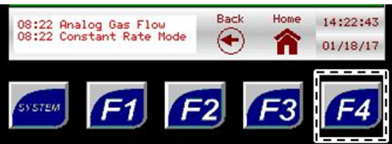
TOOLBAR	FUNCTION KEYS
	
<p>Alarms View any active alarms.</p>	<p>F1 Key Takes you to the Home screen.</p>
	
<p>Back Button Takes you back one (1) level in the menu tree to the previous screen.</p>	<p>F2 Key Takes you to the Current Alarms screen.</p>
	
<p>Home Button Takes you to the Home screen.</p>	<p>F3 Key Takes you to the Logging Setup screen.</p>
	
<p>Current Date and Time This is the current date and time in the odorizer. It can be changed from any screen.</p>	<p>F4 Key Starts and stops the auto scroll function.</p>



The toolbar appears on every screen except the Home screen.



If nothing on the screen is pressed for a certain amount of time, the sleep function will cause the backlight on the screen to turn off. To wake up the controller, press anywhere on the screen or press one of the function keys.

Viewing the Current Alarms



From any screen, press the F2 function key to go to the Current Alarms screen (Figure 12).

Figure 12: Current Alarms Screen

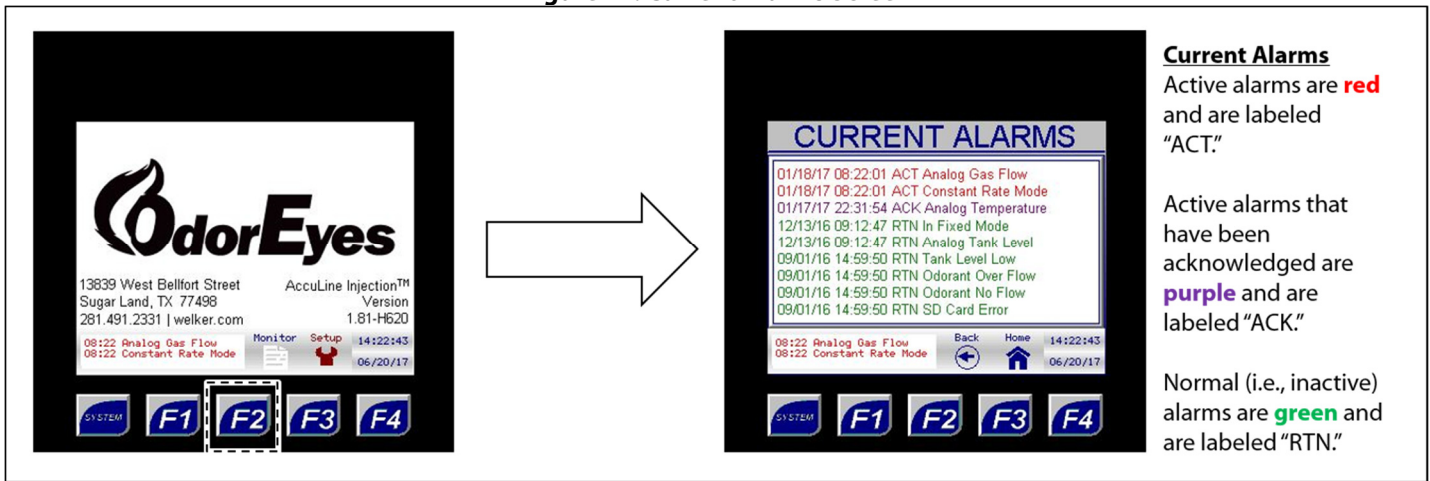

Table 4: Current Alarms

Analog Flow	Can only be active if Analog Input method is selected.
Pulse Flow	Can only be active if Pulse Input method is selected.
Constant Rate	Can only be active if Constant Rate mode is specified as the desired fail mode. The controller will enter this gas flow fail mode when there is a gas flow signal loss.
Shutdown Mode	Can only be active if Shutdown Mode is specified as the desired fail mode. The controller will enter this gas flow fail mode when there is a gas flow signal loss.
Fixed Rate	Can only be active if Fixed mode is enabled.
Tank Level	Can only be active if an electronic level transmitter is used to track the odorant tank level and the controller loses the 4–20 mA signal from the transmitter. NOTE: If this alarm is active, the controller will automatically switch to the odorant flow method to track the odorant tank level. The controller will use the value of odorant in the tank and subtract the appropriate volume with each stroke.
Tank Low Level	Active if the odorant tank level has dropped below the specified value.
P1 Overflow	Active if the pump output for the last ten (10) strokes exceeds the allowable average deviation.
P1 Low Flow	Active if the pump output for the last ten (10) strokes is below the allowable average deviation.
P1 No Flow	Active if after ten (10) strokes there is no output from the pump.
Dual Pump Mode	Indicates the odorizer is currently actuating both pumps.
SD Card Error	Active if SD Card Data Logging is enabled but no micro SD card is installed.

3.2 Navigating the Monitor Menus



Through the Monitor menu, the user can access the Rates & Totals, Pump Stats, Tank Level, System I/O, Local Audit Trail, and Local Alarms Log to view current information for the odorizer.



Monitor screens are information screens: no values can be changed from these screens.

Figure 13: Monitor Menu Submenus

OdorEyes
 13839 West Bellfort Street Sugar Land, TX 77498
 281.491.2331 | welker.com
 AccuLine Injection™ Version 1.81-H620
 141222435
 06/20/17

MONITOR MENU

- Rates & Totals**
Enter this submenu for an overview of system performance.
- System I/O**
Enter this submenu to view the current status of the digital inputs, digital outputs, and analog inputs in the system.
- Pump Stats**
Enter this submenu to view the current sample pump statistics.
- Local Audit Trail**
Enter this submenu to view the audit trail, which is stored in the system's internal memory and to the SD card if SD Card Data Logging is enabled.
- Tank Level**
Enter this submenu to view the current level and temperature of odorant in the tank.
- Local Alarms Log**
Enter this submenu to view the alarms log, which is stored in the system's internal memory and to the SD Card Data Logging is enabled.

Rates & Totals



The Rates & Totals submenu provides the user with an overview of system performance.

Figure 14: Monitor Menu – Rates & Totals



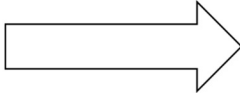

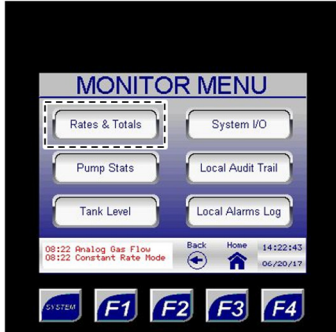

Rates & Totals
Screen displays an overview of system performance.

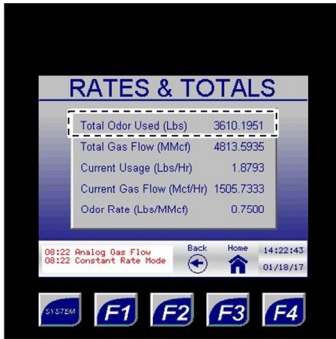

Total Odor Used (Lbs)
The total number of pounds of odorant that have been pulsed into the pipeline since the system was last reset.

This value must occasionally be manually reset at a time interval determined by the user.

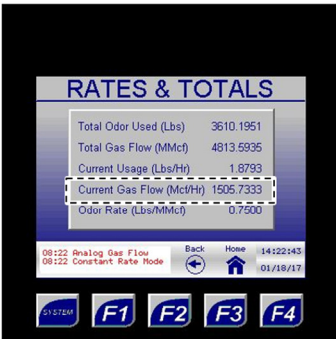

Current Gas Flow (Mcf/Hr)
The current volume of gas flowing in the pipeline relative to time.

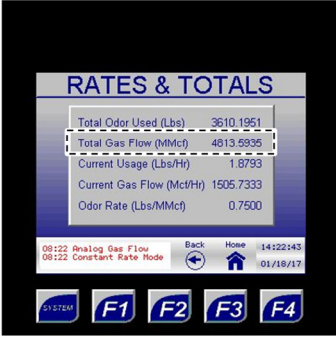

Total Gas Flow (MMcf)
The total amount of gas flow the odorizer has seen since the system was last reset.

This value must occasionally be manually reset at a time interval determined by the user.

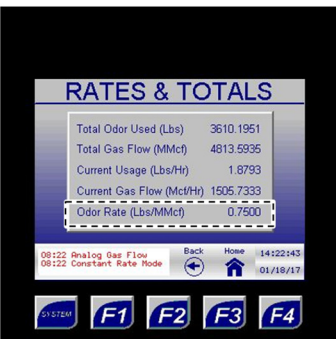

Odor Rate (Lbs/MMcf)
The current odorant usage by the system relative to gas flow (lb/MMcf).



Current Usage (Lbs/Hr)
The current odorant usage by the system relative to time.



If the system status totals are used to track system performance, they should be periodically reset through the System Control submenu (Figure 22).

Figure 15: Monitor Menu – Pump Stats

Pump Stats
Screen displays an overview of the current sample pump statistics.

Pump In Service
This indicates which pump is currently injecting odorant into the pipeline.
Note this system has one (1) pump.

Pump Cycle Time
This indicates the current cycle time (in seconds) of the pump in service.

Next Pump Stroke In
This is a countdown timer until the next stroke of the pump in service. The countdown time is given in seconds.

CC
The volume of odorant the pump injected on its last stroke. The volume is given in cubic centimeters (cc).

% Dev
The 10-stroke average deviation of the pump from the user's set point.
If the pump is below its set point, it will show a negative percentage.
If the pump is above its set point, it will show a positive percentage.



T Strks
The total number of strokes for the pump since the system was last reset by the user.
This should be reset after performing pump maintenance.

Odorant Tank Level

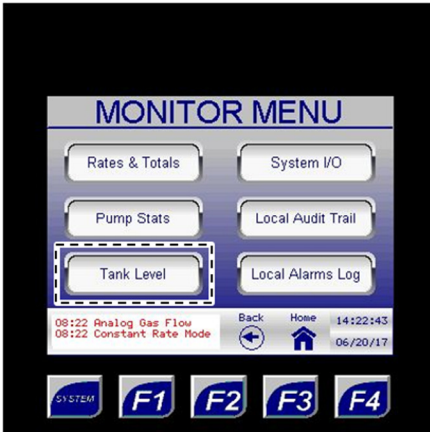
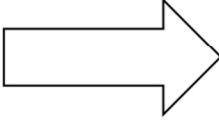

The Tank Level submenu is not applicable for this system.

Figure 16: Monitor Menu – Tank Level



Tank Level
Enter this submenu to view the current level and temperature of odorant in the tank.



This screen displays the amount of odorant remaining in the odorant supply tank in inches, US gallons, and pounds.

These values will either be from a transmitter or a calculation based on odorant usage.

Odorant Remaining	
Inches	18.0
Gallons	14.4
Pounds	97.6
Percent	41.1



The System I/O submenu provides the user with an overview of the current status of digital inputs, digital outputs, and analog inputs in the system.

Figure 17: Monitor Menu – System I/O, 1 of 2

System I/O
Enter this submenu to view the current status of the digital inputs, digital outputs, and analog inputs in the system.

This will close when the flow switch solenoid opens.

This will close when the pump is injecting odorant.

This will close when the first customer meter on the pipeline receives a gas flow signal.

This indicates the alarm status. The alarm status is normally closed.

Category	Item	Value	Alarm Status
Analog Inputs	Gas Flow (R1)	25322	Normally Closed
	Gas Flow (R1)	9931	Normally Closed
	Tank Level (R3)	6711	Normally Closed
	Odorant Meter	6711	Normally Closed
Digital Inputs	Flow Switch (R1)	Green	Normally Closed
	Gas Flow 1 (R2)	Green	Normally Closed
	Not Used (R3)	Green	Normally Closed
	Not Used (R4)	Green	Normally Closed
Digital Outputs	Sol Pump 1 (R1)	Green	Normally Closed
	Sol Pump 2 (R2)	Green	Normally Closed
	Alarm N.C. (R3)	Green	Normally Closed
	Not Used (R4)	Green	Normally Closed

Figure 18: Monitor Menu – System I/O, 2 of 2

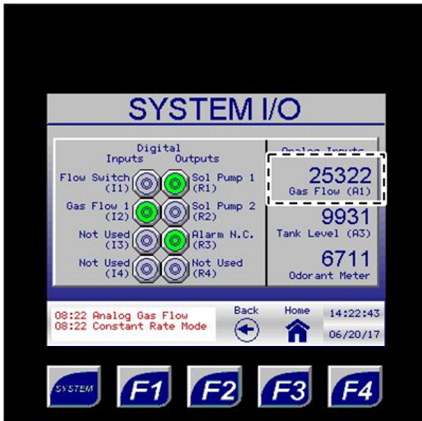
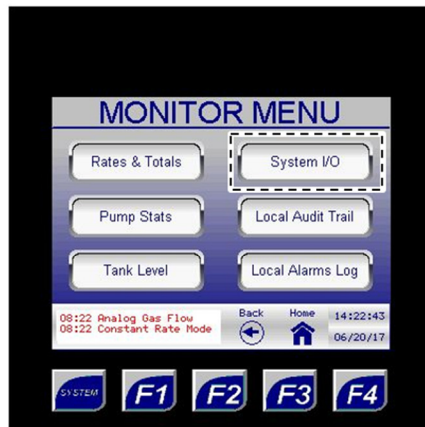

This analog signal is the raw count coming into the odorizer after the signal has been converted from milliamps. This value will vary according to the output from the customer gas flow meter.

Analog Input Conversion	
Signal (mA)	Raw Count
4	6400
20	32000

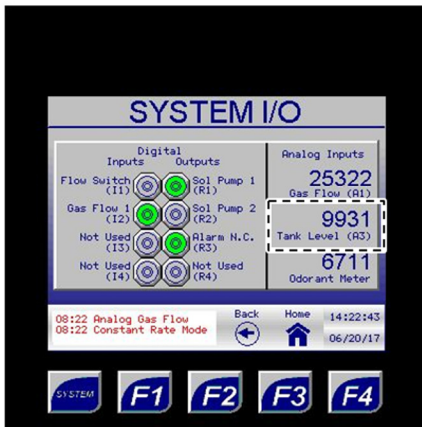

This analog signal is the raw count coming out of the odorizer after the signal has been converted from milliamps. This value will vary according to customer specifications.

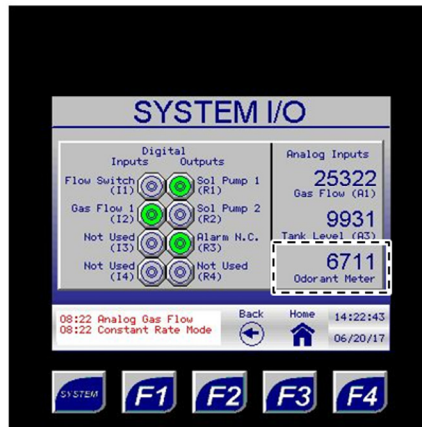

This value indicates how many high-speed pulses were received from the odorant flow meter. This value appears after each pump stroke and reverts to zero (0) after two (2) seconds.

Local Audit Trail



From the Local Audit Trail submenu, the user can access the audit trail records stored in internal memory. Up to 600 audit trail records can be stored and viewed.



If SD Card Data Logging is enabled, the audit trail records will also be stored to the installed micro SD card. The micro SD card is equipped with 2–8 GB of storage.

Figure 19: Monitor Menu – Local Audit Trail

Local Audit Trail
Enter this submenu to view the audit trail, which is stored in the system's internal memory and to the SD card if SD Card Data Logging is enabled.

Press the up or down arrow to scroll through the audit trail records.

Up to 600 audit trail records can be stored in the system's internal memory.

If SD Card Data Logging is enabled, these records will also be stored to the SD card.

The audit trail record number.

The date and time the audit trail record was captured.

Total Gas Flow (MMcf)
Total amount of gas flow the odorizer saw during the user-defined time frame.

Odor Rate for Period (Lbs/MMcf)
Total odorant usage by the system relative to gas flow (lb/MMcf) (a.k.a. injection rate) during the user-defined time frame.

Total Odor Used (Lbs)
Total amount of odorant in pounds that was injected during the user-defined time frame.

Odorant Remaining (Gal)
Total amount of odorant remaining in US gallons at the end of the user-defined time frame.

Local Alarms Log



From the Local Alarms Log submenu, the user can access the alarm logs stored in internal memory. Up to 428 alarm logs can be stored and viewed.



If SD Card Data Logging is enabled, the alarm logs will also be stored to the installed micro SD card. The micro SD card is equipped with 2–8 GB of storage.

Figure 20: Monitor Menu – Local Alarms Log

Local Alarms Log
Enter this submenu to view the alarms log, which is stored in the system's internal memory and to the SD card if SD Card Data Logging is enabled.

The alarm code.

The name of the alarm.

Press the up or down arrow to scroll through the alarm log records.

Up to 428 alarm log records can be stored in the system's internal memory.

If SD Card Data Logging is enabled, these records will also be stored to the SD card.

The alarm log record number.

The date and time the alarm occurred or cleared.

3.3 Navigating the Setup Menus



Through the Setup menu, the user can access the System Control, Odorant Pump, Controller Options, Gas Flow Signal, Odorant Tank, and Logging Setup submenus and change numeric and/or text values that alter the parameters and features of the odorizer.



Changing numeric and/or text values in the Setup submenus will alter how the system operates.

Figure 21: Setup Menu Submenus

OdorEyes
13839 West Bellfort Street Sugar Land, TX 77498
281.491.2331 | welker.com
AccuLine Injection™ Version 1.81-H520
08:22 Analog Gas Flow 14:22:43
08:22 Constant Rate Mode 06/20/17

System Control
Enter this submenu to configure the operation of the odorizer.

Gas Flow Signal
Enter this submenu to set the parameters for the gas flow signal and set the fail mode.

Odorant Pump
Enter this submenu to set the parameters for the odorant pump(s).
Note this system has one (1) pump.

Odorant Tank
Enter this submenu to set the parameters for the odorant tank and temperature transmitter.

Controller Options
Enter this submenu to customize screen operation, set the date and time, configure analog output, and configure the Modbus.

Logging Setup
Enter this submenu to enable or disable data logging to the SD card and monitor the status of the SD card.

Setup Menu
Access setup submenus to change set point values in the odorizer.
All setup screens have a red background.

Changing Values on Setup Screens

Numeric Values

1. To change a numeric value, press on the value to be changed. A keypad will appear on the screen.
2. Type the new value using the keypad.
3. Once the new numeric value has been entered, press ENTER to save the changes.



If the new value entered is outside the range of allowable values, the value will revert to the previous value once ENTER is pressed. The keypad will stay active, allowing another value to be entered.

Text Values

4. To change a text value, press on the value to be changed. A dropdown menu will appear on the screen.
5. Scroll through the value's options using the arrow keys in the dropdown menu.
6. Highlight the desired text value, and then press ENTER to save the changes.



If a mistake is made while entering the new value or if the value does not need to be changed, press the home button to discard the changes and return to the Home screen.

System Control



Through the System Control submenu, the user can set the general parameters for the odorizer.

Figure 22: Setup Menu – System Control



System Control
Enter this submenu to configure the operation of the odorizer.



Odor Rate Required
Set the number of pounds of odorant to pulse per million standard cubic feet (MMcf) of gas passed.

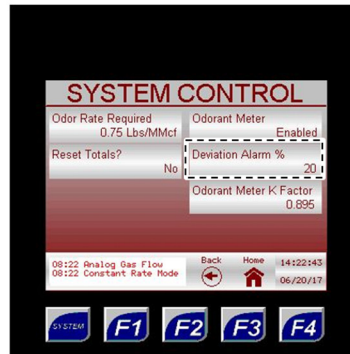

Deviation Alarm %
This is the allowable deviation the pump can work in before it will alarm for low flow or pump overflow.

The smaller this value, the more closely the user must monitor the pump and the less tolerant the system will be of pump output variations.

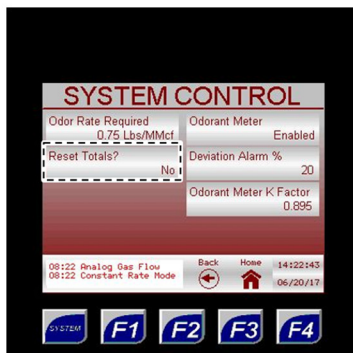

Reset Totals
Toggling this field to “Yes” causes the gas flow and odorant flow totals to be reset.

Once reset, this field will automatically revert to “No.”

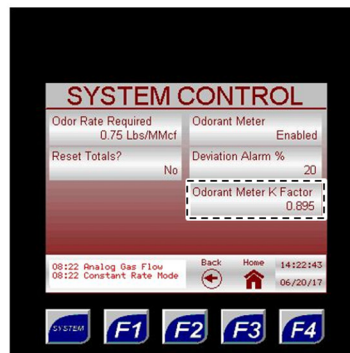

Odorant Meter K Factor
This value is factory-set for the odorant flow meter. This value represents how many revolutions of the meter it takes to equal 1 cc of liquid.

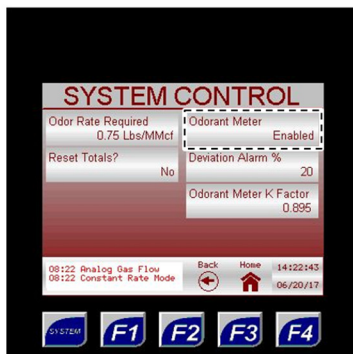

Odorant Meter
When enabled, each stroke of the pump is measured, monitored, and recorded, and the stroke frequency will adjust based on this value.

When disabled, each stroke of the pump is presumed to be at its set value.

Odorant Pump



Through the Odorant Pump Submenus, the user can input information for the injection pump.

Figure 23: Setup Menu – Odorant Pump

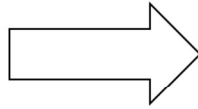

Odorant Pump
Enter this submenu to set the parameters for the odorant pump.

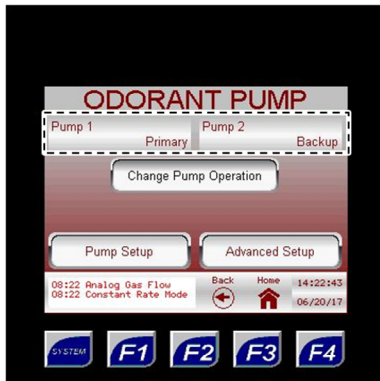

Pump 1
View the current operation of the pump.

Note this system has one (1) pump.

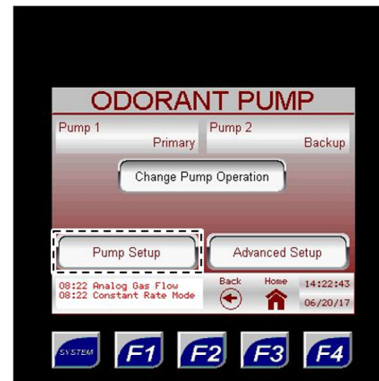

Pump Setup
Enter this submenu to set the known output of the pump, manually stroke the pump, reset the total number of pump strokes, and reset the pump alarms.

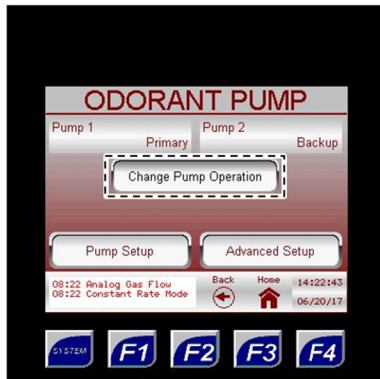

Change Pump Operation
Change the current operation of the pump as displayed above this button.

The pumps can be set up according to the Pump Operation Configurations table.

Note this system has one (1) pump.

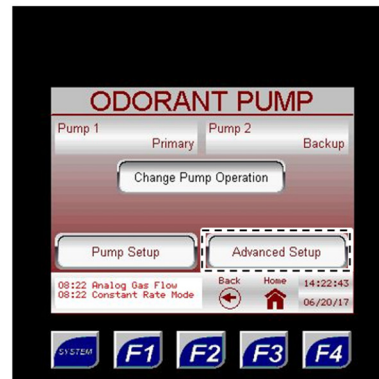

Advanced Setup
Enter this submenu to set the minimum cycle time of the pumps and enable both pumps to stroke together.

Note this system has one (1) pump.

Pump Operation Configurations	
Pump 1	Pump 2
None	None
Primary	None
None	Primary
Primary	Backup
Backup	Primary

Figure 24: Odorant Pump – Pump Setup

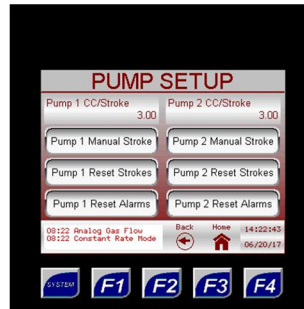
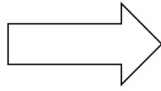
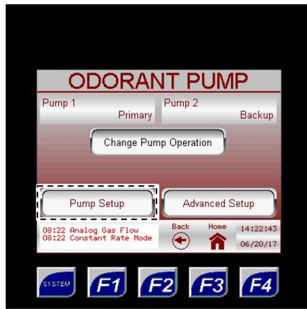

Pump Setup
Enter this submenu to set the known output of the pump, manually stroke the pump, reset the total number of pump strokes, and reset the pump alarms.

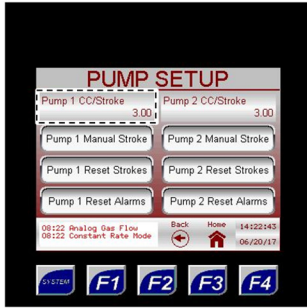

Pump CC/Stroke
Set the known output of the pump in cubic centimeters (cc).

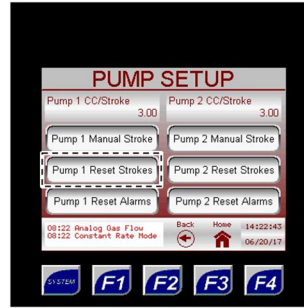

Reset Strokes
Pressing this button will reset the total number of strokes for the pump. This option is to assist in the tracking and scheduling of pump maintenance.

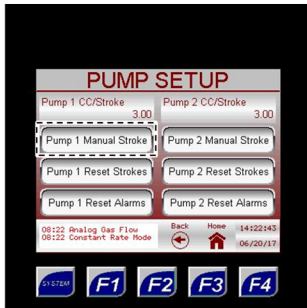

Manual Stroke
Manually stroke the pump.

When the pump is set to stroke it will be highlighted until the first available opportunity, at which time it will stroke the pump. After a manual pump stroke, this field will revert to its normal state.

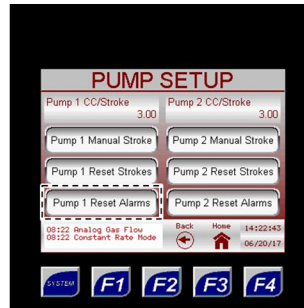

Reset Alarms
Pressing this button will reset the pump alarms, which also resets the average deviation to 0%. Alarms are typically reset after maintenance has been performed on the pump and it is put back into service. After being reset, this field will revert to its normal state.

Figure 25: Odorant Pump – Advanced Setup

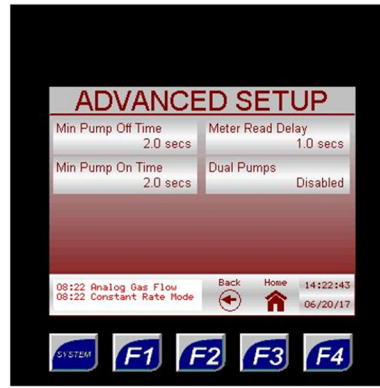
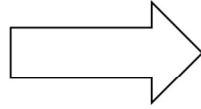
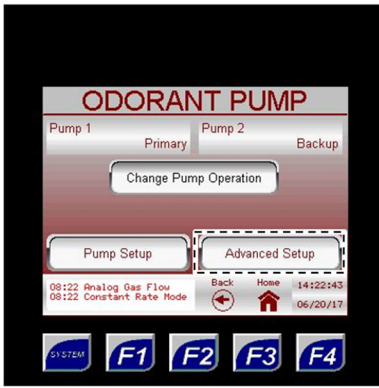

Advanced Setup

Enter this submenu to set the minimum cycle time of the pumps and enable both pumps to stroke together.

Note this system has one (1) pump.

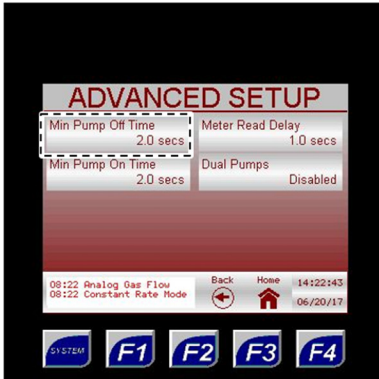

Min Pump Off Time

The minimum amount of time required to reset the pump before the next stroke.

This value is factory-set.

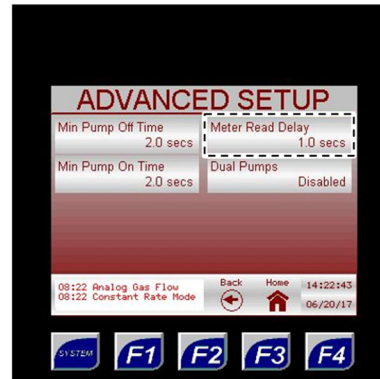

Meter Read Delay

The amount of time in seconds the meter is given to read the pump output and respond to the controller.

This value is factory-set.

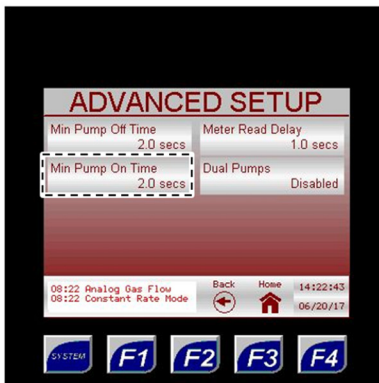

Min Pump On Time

The minimum amount of time required to stroke the pump.

This value is factory-set.



Dual Pumps

This option is factory-set to disabled, as the system has one (1) pump.

Controller Options



Through the Controller Options submenus, the user can customize the screen operation and set up communication for the controller.

Figure 26: Setup Menu – Controller Options

Controller Options
Enter this submenu to customize screen operation, set the date and time, configure analog output, and configure the Modbus.

Auto Scroll Setup
Enter this submenu to customize screen operation.

Port MJ1 Setup
Enter this submenu to configure port MJ1 and view its current status.

Date/Time Setup
Enter this submenu to change the date and time values and view the version of software the controller is running.

Port MJ2 Setup
Enter this submenu to configure port MJ2 and view its current status.

Analog Input Setup
If the gas flow input signal is analog and if the electronic level transmitter method is used to track the odorant tank level, enter this submenu to set the applicable parameters.

Ethernet Setup
Enter this submenu to configure the Ethernet connection and view its current status.

Analog Output Setup
Enter this submenu to configure the analog output if the customer desires to receive the odorization rate in the form of an analog signal.

The controller is capable of outputting to two (2) different receivers.

Auto Scroll Setup

Figure 27: Controller Options – Auto Scroll Setup

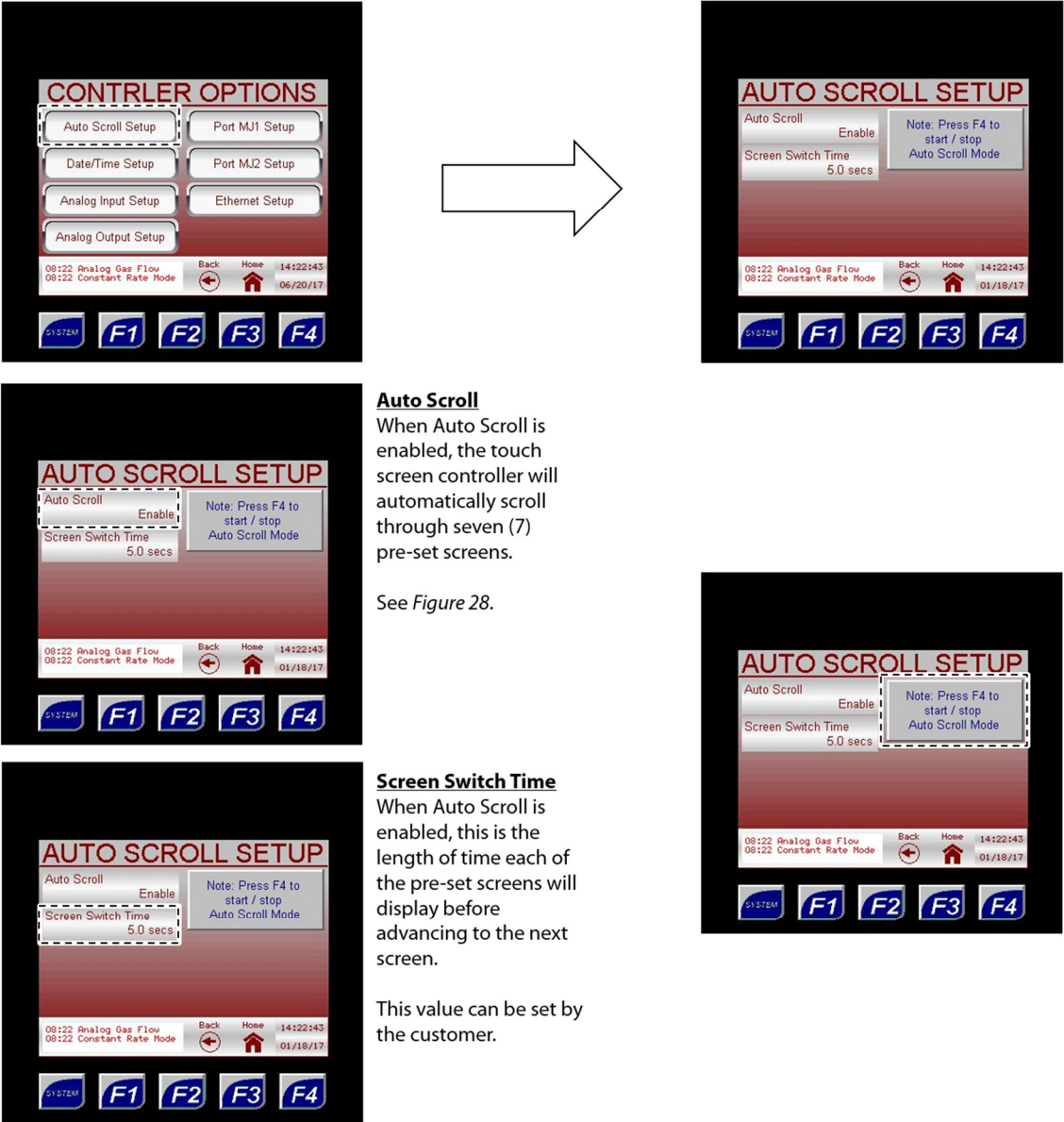

Auto Scroll Setup
Enter this submenu to customize screen operation.

Auto Scroll
When Auto Scroll is enabled, the touch screen controller will automatically scroll through seven (7) pre-set screens.

See Figure 28.

Screen Switch Time
When Auto Scroll is enabled, this is the length of time each of the pre-set screens will display before advancing to the next screen.

This value can be set by the customer.

Auto Scroll can be started or stopped at any time by pressing the F4 function key.



The Auto Scroll behavior can also be started by pressing the F4 function key (Figure 11).

Figure 28: Auto Scroll Pre-Set Screens

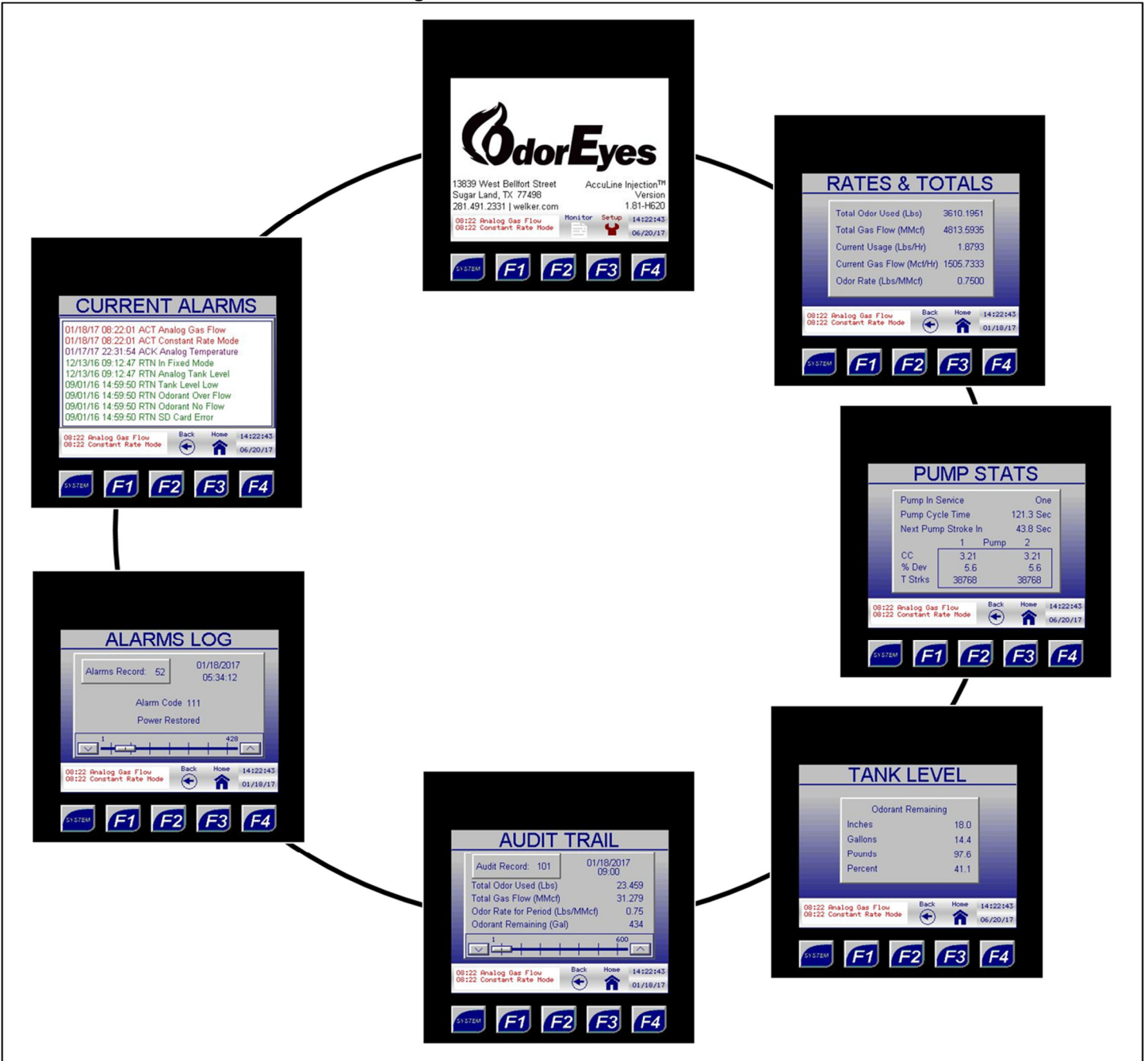

Figure 29: Controller Options – Date/Time Setup

CONTRLER OPTIONS

- Auto Scroll Setup
- Port MJ1 Setup
- Date/Time Setup**
- Port MJ2 Setup
- Analog Input Setup
- Ethernet Setup
- Analog Output Setup

08:22 Analog Gas Flow Back Home 14:22:43
08:22 Constant Rate Mode ← ↗ 06/20/17

SYSTEM F1 F2 F3 F4

→

DATE/TIME SETUP

Time 14:22:43 Program Version 1.81
Date 06/20/2017

08:22 Analog Gas Flow Back Home 14:22:43
08:22 Constant Rate Mode ← ↗ 06/20/17

SYSTEM F1 F2 F3 F4

Time
Change the current time here.

The backup battery ensures that the current date and time will not be lost.

Note that the clock does not account for daylight saving time.

Program Version
This is the version of software the controller is currently running.

Date
Change the current date here.



The date and time can also be edited by selecting the current date and time on any screen (Figure 11).

Figure 30: Controller Options – Analog Input Setup

The figure consists of five screenshots arranged in a grid. The first screenshot shows the 'CONTRLER OPTIONS' menu with 'Analog Input Setup' highlighted. An arrow points to the second screenshot, 'ANALOG INPUTS', which shows the default configuration: Input 1 (A1) for Gas Flow and Input 3 (A3) for Tank Level. The third screenshot shows 'Input 2 (A2)' selected and disabled. The fourth screenshot shows 'Input 4 (A4)' selected and disabled. The fifth screenshot shows the 'ANALOG INPUTS' screen again, with the default configuration highlighted.

Analog Input Setup
If the gas flow input signal is analog and if the electronic level transmitter method is used to track the odorant tank level, enter this submenu to set the applicable parameters.

Default Configuration
Analog input port 1 (A1) is the default port for the gas flow signal.

Analog input port 3 (A3) is the default port for the tank level transmitter.

Input 4 (A4)
Analog input port 4 (A4) is left open and disabled.

If the assigned analog input port for the gas flow signal or tank level transmitter must change (e.g., in the event of port damage), A4 can be enabled and the analog signal physically moved to this port.

Input 2 (A2)
Analog input port 2 (A2) is left open and disabled.

If the assigned analog input port for the gas flow signal or tank level transmitter must change (e.g., in the event of port damage), A2 can be enabled and the analog signal physically moved to this port.



The Analog Output Setup submenu is not applicable for this system.

Figure 31: Controller Options – Analog Output Setup

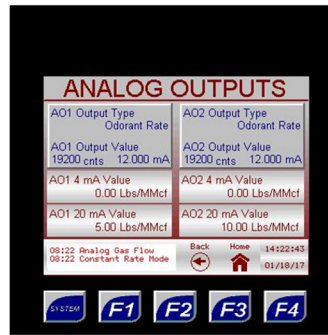
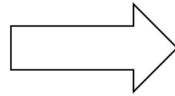

Analog Output Setup
Enter this submenu to configure the analog output if the customer desires to receive the odorization rate in the form of an analog signal.

The controller is capable of outputting to two (2) different receivers.

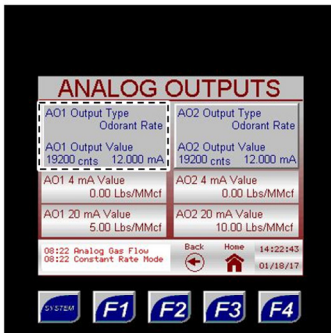

AO1 Output Type
The analog output signal to the first receiver.

AO1 Output Value
The current analog output signal to the first receiver, indicating the current odorization rate (lb/MMcf).

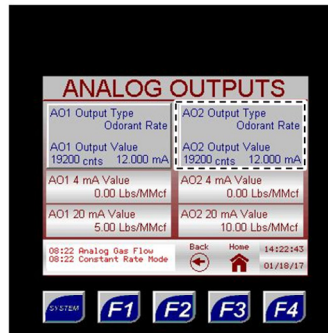

AO2 Output Type
The analog output signal to the optional second receiver.

AO2 Output Value
The current analog output signal to the optional second receiver, indicating the current odorization rate (lb/MMcf).

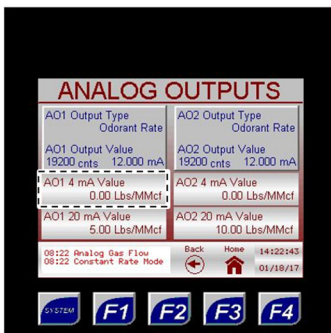

AO1 4 mA Value
Touch to configure the 4 mA signal for the analog output.

In most cases, this will be set to zero (0) lb/MMcf.

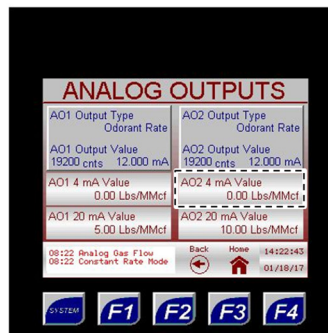

AO2 4 mA Value
Touch to configure the 4 mA signal for the analog output.

In most cases, this will be set to zero (0) lb/MMcf.

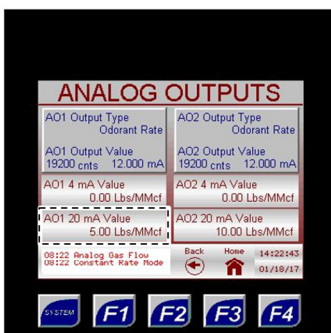

AO1 20 mA Value
Touch to configure the 20 mA signal for the analog output.

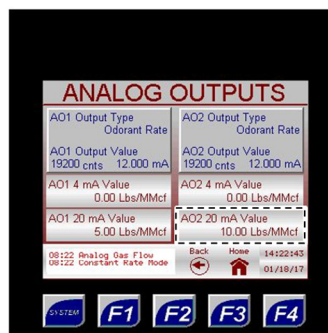

AO2 20 mA Value
Touch to configure the 20 mA signal for the analog output.

Analog Output Conversion	
Signal (mA)	Raw Count
4	6400
20	32000

Figure 32: Controller Options – Port MJ1/MJ2 Setup

Port MJ1 Setup
Enter this submenu to configure port MJ1 and view its current status

Port MJ2 Setup
Enter this submenu to configure port MJ2 and view its current status

Port Type
The port type can be set to:

- RS-232
- RS-485
- Modem
- Ethernet
- Fiber A
- Fiber B
- GSM Dual
- GSM Quad
- Radio 900 MHz
- Radio Zigbee

Stop Bits
This value can be set to 1 or 2.

Baud
The available baud rate ranges from 300 to 115200.

Handshake
The required handshake can depend on the Port Type and/or Protocol used.

The handshake can be set to:

- None
- Xon / Xoff
- Hardware
- Multidrop Full
- Multidrop Half
- Radio Modem

MJ1 Modbus Setup
Enter this submenu to complete configuration of port MJ1 and view its current status.

MJ2 Modbus Setup
Enter this submenu to complete configuration of port MJ2 and view its current status.

Parity
This value can be set to None, Odd, or Even.

Data Bits
This value can be set to 7 or 8.

Figure 33: Port MJ1/MJ2 Setup – MJ1/MJ2 Modbus Setup

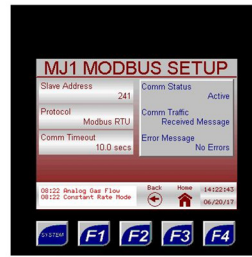
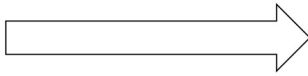
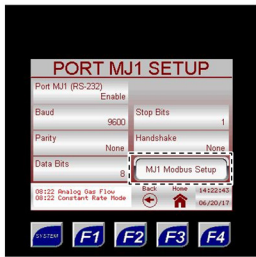

MJ1 Modbus Setup
Enter this submenu to complete configuration of port MJ1 and view its current status.

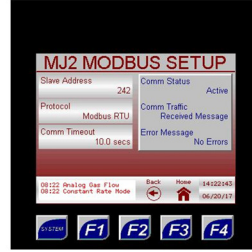
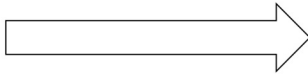
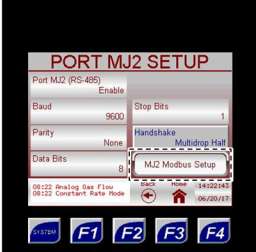

MJ2 Modbus Setup
Enter this submenu to complete configuration of port MJ2 and view its current status.

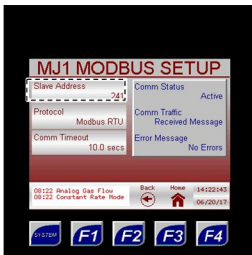

Slave Address
This value is the Modbus slave address for the odorizer.

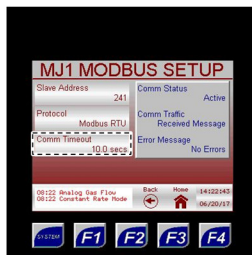
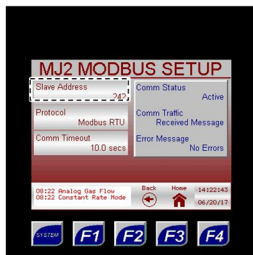

Comm Timeout
This value is the timeout between Modbus messages (in seconds).

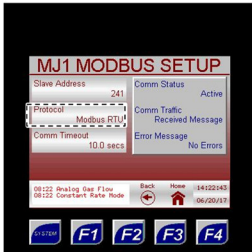
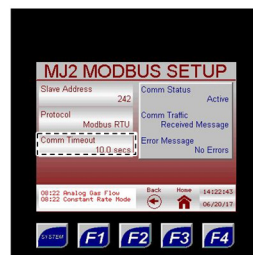

Protocol
The protocol setting applies to port MJ1 or MJ2 only.

The protocol can be set to:

- CsCAN
- Generic
- Modbus RTU
- Modbus MSCII
- Modbus TCP

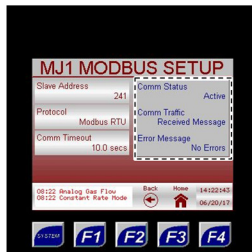
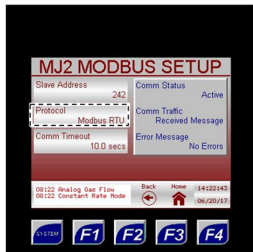

These fields display the current status of the Modbus for troubleshooting purposes.

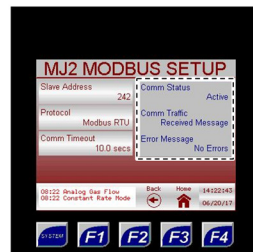

Figure 34: Controller Options – Ethernet Setup

The figure consists of five screenshots arranged in a grid. The first screenshot shows the 'CONTRLER OPTIONS' menu with 'Ethernet Setup' highlighted. An arrow points to the second screenshot, 'ETHERNET SETUP', which shows the configuration fields. The third screenshot highlights the 'IP Address' field, the fourth highlights the 'Default Gateway' field, and the fifth highlights the 'Subnet Mask' field. Each screenshot includes a status bar at the bottom with system information and function keys (F1-F4).

Ethernet Setup
Enter this submenu to configure the Ethernet connection and view its current status.

IP Address
Manually assign an IP address.

Pressing this field will bring up an on-screen keyboard for address entry.

Default Gateway
Manually assign the default gateway.

Pressing this field will bring up an on-screen keyboard for gateway entry.

Subnet Mask
Manually assign the subnet mask.

Pressing this field will bring up an on-screen keyboard for subnet mask entry.

This column displays diagnostic information about the Ethernet connection.

Gas Flow Signal



Through the Gas Flow Signal submenus, the user can set up the parameters of the odorant gas flow input signal.

Figure 35: Setup Menu – Gas Flow Signal

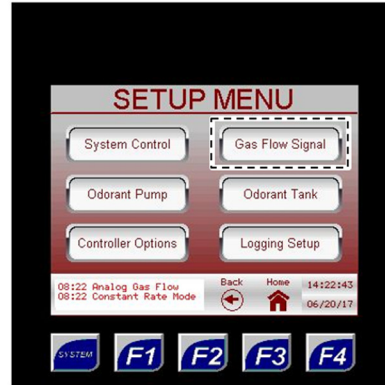
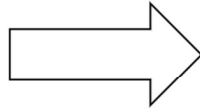
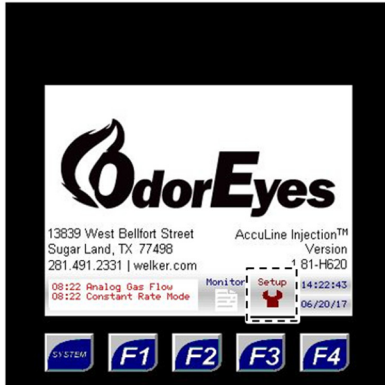

Gas Flow Signal

Enter this submenu to set the parameters for the gas flow signal and set the fail mode.

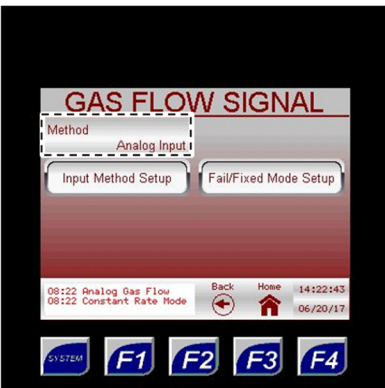

Method

Toggle this field to switch between the three (3) methods for the gas flow input signal:

1. analog input
2. pulse input
3. Modbus input

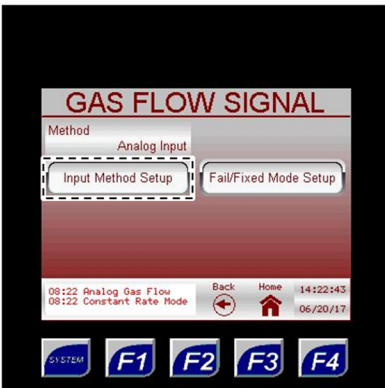

Input Method Setup

Enter this submenu to set up the applicable parameters for the chosen input method.

See Figure 36.

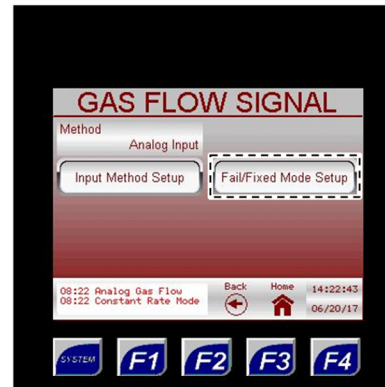

Fail/Fixed Mode Setup

Enter this submenu to select the desired fail mode, enable or disable the fixed mode, and set up applicable parameters.

See Figure 37.

Figure 36: Gas Flow Signal – Input Method Setup

Input Method Setup
Enter this submenu to set up the applicable parameters for the chosen input method.

Current Gas Flow
This value is the current gas flow signal for the pipeline (Mcf/h).

Pulses/Pump Stroke
The system automatically calculates how many gas flow input signals it will accept before the pump is stroked.

This value is used for the pulse input method only and is not a changeable value.

Min Flow Rate
If analog input is used, this value is the 4 mA signal.

If pulse input is used, this value is the minimum actual gas flow.

In most cases, this value comes factory-set to zero (0) Mcf/h.

Pulse Input Gas Volume
This value is the total standard cubic feet of gas that each pulse input to the controller represents.

This value is used for the pulse input method only.

Max Flow Rate
If analog input is used, this value is the 20 mA signal.

If pulse input is used, this value is the maximum actual gas flow.

Modbus Input Flow
If the Modbus input method is used, this is the value the Modbus is downloading for the flow rate (Mcf/h).

This value can be changed here for testing purposes.

AI Zero Gas Flow Cutoff
This value is only active if the analog input method is used.

Any value below this gas flow low cutoff value (in milliamps) will be treated as zero gas flow (0 Mcf/h).



If the gas flow signal will be analog, the analog signal must be 4–20 mA powered by the user.

If the gas flow signal will be pulse, the pulse will be a digital pulse powered by the controller.

If the gas flow signal will be Modbus, the Modbus input will be a value downloaded from the Modbus master device in Mcf/h. The Modbus Register is 43275, and the input value should be downloaded as a 32-bit float.

Figure 37: Gas Flow Signal – Fail/Fixed Mode Setup

Fail/Fixed Mode Setup
Enter this submenu to select the desired fail mode, enable or disable the fixed mode, and set up applicable parameters.

Fail Mode Setup
Select the desired fail mode and set up applicable parameters.

Fixed Mode Setup
Enable or disable the fixed rate mode.

Method
Toggle between two (2) fail modes:
 1. constant rate mode: the system will act as a timer, pulsing odorant into the pipeline at the customer-specified rate
 2. shutdown mode: the system will halt odorization and will not start again until a gas flow signal is received

Constant Rate Flow
This value is only active if the fail mode is set to constant rate mode.

In the event of a gas flow signal loss, the system will continue to odorize at the constant rate set here (Mcf/h).

Pulse/Modbus Cutoff
If the pulse input method is used, this value is the amount of time (in seconds) the system will wait between pulse inputs before it will determine there is a gas flow signal loss and go into the set fail mode.

Fixed Alarm Flow Rate
When Fixed Mode is enabled, the flow rate (Mcf/h) must be manually set. The system will odorize based on this rate until the Fixed Mode is disabled.



Setting the Fail Mode to Shutdown will halt odorization until the alarm is cleared.
Setting the Fail Mode to Constant Rate will allow odorization to continue at the specified rate.



If the gas flow value does not change during the Pulse/Modbus Cutoff time, the system will alarm for loss of flow and will enter the specified Fail Mode. The alarm will clear on the next pulse input or change in Modbus gas flow, and the system will resume normal operation.

Odorant tank Setup



Through the Odorant Tank submenus, the user can input information for the odorant tank.

Figure 38: Setup Menu – Odorant Tank

Odorant Tank
Enter this submenu to set the parameters for the odorant tank and temperature transmitter.

Method
Toggle this field to switch between the two (2) methods for tracking the odorant tank level:
 1. odorant flow
 2. electronic level transmitter

Low Level Alarm
The low level alarm set point is a percent value at which the system will trigger an alarm for low odorant level in the tank.

Tank Level Setup
Enter this submenu to set up the parameters for how the tank level will operate.

See *Figure 39*.

Tank Volume Setup
Enter this submenu to view the tank volume settings and access the strapping tables.

See *Figure 40*.



When using an electronic level transmitter to track the odorant tank level, the Method should be set to Transmitter. When estimating the odorant tank level based on odorant usage, the Method should be set to Odorant Flow.



Note this system is not equipped with a level transmitter.

Figure 39: Odorant Tank – Tank Level Setup

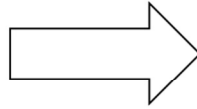

Tank Level Setup

Set up the parameters for how the tank level will operate.



Current Level

View the current level of the tank in inches and US gallons.

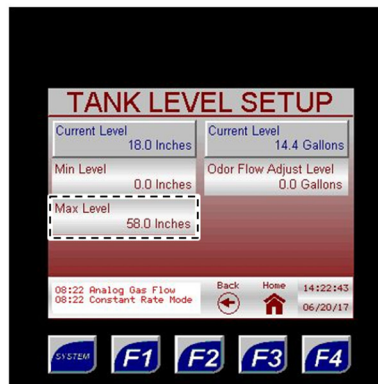

Max Level

If the electronic level transmitter method is used, this value is the 20 mA signal.



Min Level

If the electronic level transmitter method is used, this value is the 4 mA signal.

This value is typically factory-set at 0.0 inches.

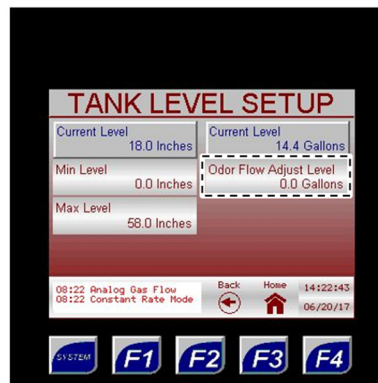

Odor Flow Adjust Level

If the odorant flow method is used, the current tank level can be manually adjusted.

The Current Level numeric value cannot be directly changed. Instead, the user must enter a value in the Odor Flow Adjust Level field to increase or decrease the Current Level by the specified amount.



- To decrease the Current Level, enter the volume to be subtracted from the current level as a negative number in the Odor Flow Adjust Level field, and then press ENTER to save the changes. The Current Level should have decreased by the amount entered, and the Odor Flow Adjust Level should have reverted to 0.0 Gallons.
- To increase the Current Level, enter the volume to be added to the current level in the Odor Flow Adjust Level field, and then press ENTER to save the changes. The Current Level should have increased by the amount entered, and the Odor Flow Adjust Level should have reverted to 0.0 Gallons.

Figure 40: Odorant Tank – Tank Volume Setup

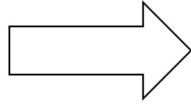

Tank Volume Setup

Enter this submenu to view the tank volume settings and access the strapping tables.



Size

This is the volume of the tank in US gallons.



Odorant Density

The odorant density will vary according to the odorant used.

The odorant density should be published by the odorant manufacturer in pounds/US gallons at 60 °F.



Volume Conversion

This value is the volume of liquid odorant per inch. This is used only with vertical odorant tanks.



Strapping Table

Toggle this field to enable or disable the tank strapping field.

For horizontal odorant tanks, this field should be **enabled**. For vertical odorant tanks, this field should be **disabled**.

Strapping Table Pg 1, 2, 3

If strapping is enabled, view the tank depth and tank volume for each strapping point. See Figure 41.

Figure 41: Tank Volume Setup – Strapping Tables

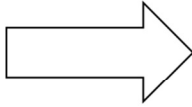

The strapping table page number.

Each page displays the tank depth in inches and the tank volume in US gallons for multiple strapping points.

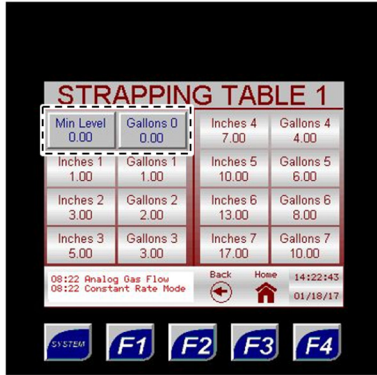

The minimum strapping point for the tank is displayed on page 1.

It is zero (0) inches and zero (0) US gallons.



The right column of each table displays the tank volume in US gallons per inch.

Each table row is a single strapping point.



The left column of each table displays the tank depth in inches.

Each table row is a single strapping point.



The maximum strapping point for the tank is displayed on the last page.

The maximum strapping point will depend on the tank size and volume.



If the odorant tank is horizontal, the strapping points will be calculated and entered at the factory.

Logging Setup



Through the Logging Setup submenu, the user can set up and monitor the data logs stored on the installed micro SD card.



If a micro SD card is installed, data will automatically be logged to the installed card when SD Card Data Logging is enabled.

Figure 42: Setup Menu – Logging Setup

Logging Setup
Enter this submenu to enable or disable data logging to the SD card and monitor the status of the SD card.

SD Card Data Logging
Must be enabled for the system to automatically log information to the installed SD card.

SD Card Access
If a micro SD card is installed to the system, its contents can be viewed from this screen.

Monitor the storage capacity of the installed SD card.

SD Card Diagnostics
Monitor the status of the installed SD card and the three (3) logs stored on the SD card:
 1. pumps log
 2. audit trail log
 3. alarms log

Local Logging Setup
Enter this submenu to view the alarm and audit record status.



If the micro SD card needs to be removed, first disable SD Card Data Logging. Failure to disable SD Card Data Logging prior to removing the micro SD card will trigger the SD Card Error alarm.



To continue data logging, insert a new micro SD card, and then enable SD Card Data Logging.

Figure 43: Logging Setup – SD Card Diagnostics

SD Card Diagnostics
Monitor the status of the installed SD card and the three (3) logs stored on the SD card:

1. pumps log
2. audit trail log
3. alarms log

SD Card Data Status
Monitor the status and storage capacity of the installed SD card.

Audit Trail File Status
Monitor the status and storage capacity of the audit trail.
A new audit log entry is created every 5 minutes.

Pumps Log File Status
Monitor the status and storage capacity of the pumps log.
A new pumps log entry is created with each stroke of the odorizer.

Alarms Log File Status
Monitor the status and storage capacity of the alarms log.
A new alarms log entry is created when an alarm occurs or clears.

Figure 44: Logging Setup – SD Card Access

SD Card Access
If a micro SD card is installed to the system, its contents can be viewed from this screen.
Contact Welker for assistance installing software updates.



Through the Local Logging Setup submenu, the user can set up and reset the data logs stored locally.

Figure 45: Logging Setup – Local Logging Setup

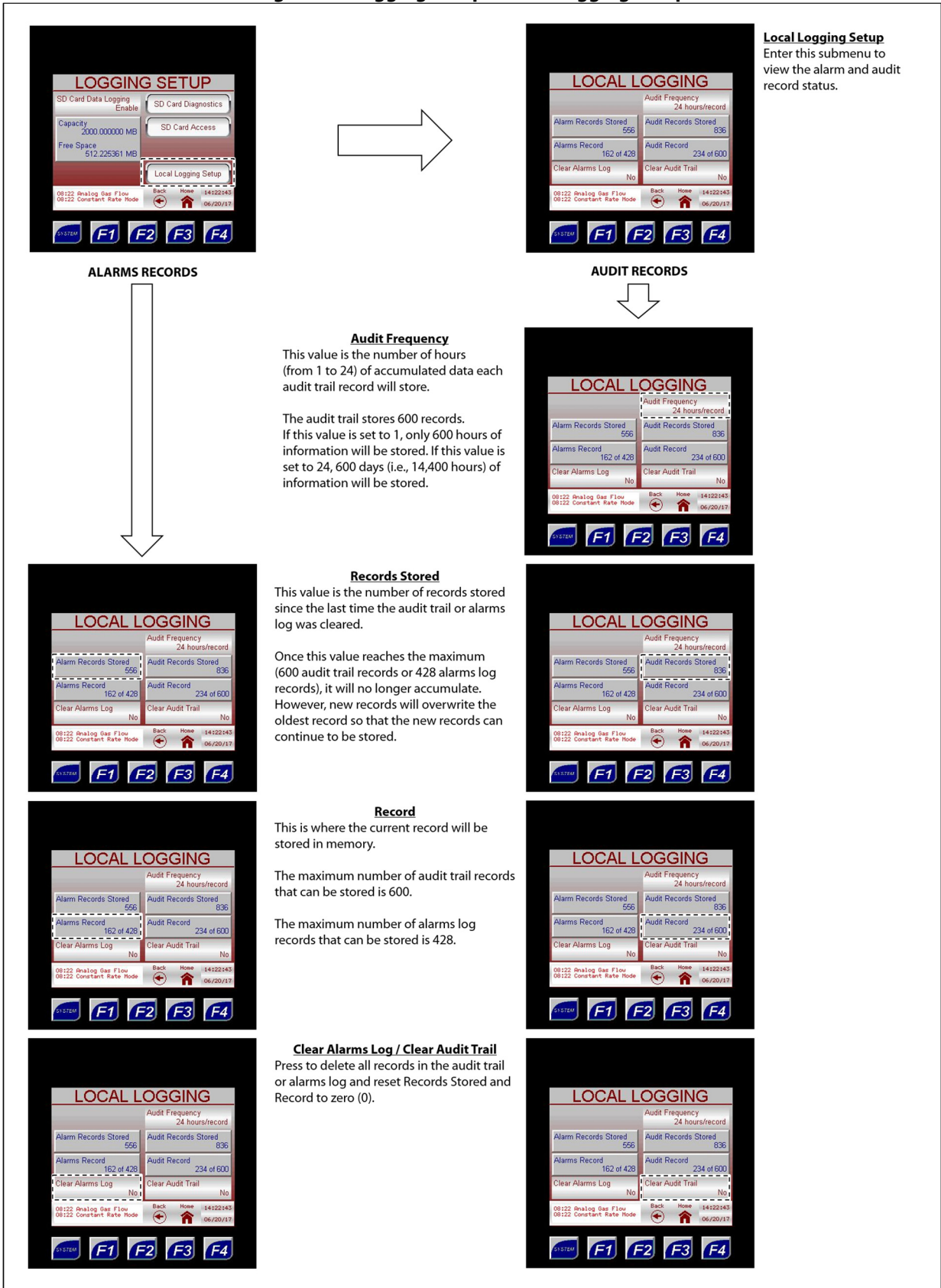

SECTION 4: MAINTENANCE

4.1 Before You Begin

1. **Refer to Appendix B, Maintenance Schedule, for the itemized Welker recommended maintenance schedule for the POC.**
2. Prior to maintenance or disassembly of the unit, it is advisable to have a repair kit available for repairs of the system in case of unexpected wear or faulty seals.



New seals supplied in spare parts kits should be lightly lubricated before being installed to ease the installation of the seals and reduce the risk of damage when positioning them on parts. Wipe excess lubricant from the seals, as it may adversely affect analytical instrument results.



For sample-exposed seals, Welker recommends non-hydrocarbon-based lubricants, such as Krytox®. For non-sample-exposed seals, Welker recommends either non-hydrocarbon-based lubricants or silicone-based lubricants, such as Molykote® 111.



After the seals are installed, the outer diameter of shafts and inner diameter of cylinders may be lubricated to allow smooth transition of parts.

3. All maintenance and cleaning of the unit should be performed on a smooth, clean surface.

4.2 Maintenance

1. During injection, monitor the system for leaks. If leaks are present, halt operation and repair as necessary.
2. Occasionally, a system component may need to be repaired or replaced for manufacturer recommended maintenance. To perform maintenance on components:
 - a. Turn OFF all electrical power to the system, if applicable.
 - b. Depressurize the system and close all valves.
 - c. Disconnect the tubing and remove individual system components for maintenance.
 - d. For complete and proper maintenance on system components, refer to their *Installation, Operation, and Maintenance (IOM) Manual*. A list of component *Installation, Operation, and Maintenance (IOM) Manuals* is available in *Appendix A, Referenced or Attached Documents*, in this manual.
 - e. After performing necessary maintenance on system components, reconnect all instrument tubing.
 - f. Reinstall the system according to the instructions in *Section 2.2, Installation*, and *Section 2.3, Start-Up Procedures*.

4.3 Troubleshooting

Table 5: POC Troubleshooting

Issues	Possible Causes	Solutions
Nothing is happening.	The battery is dead and not charging.	Ensure that the solar panel has been connected to the battery. As necessary, adjust the solar panel so that it faces the direction of the sun and is not shaded.
The BIP is not actuating properly.	<p>The pneumatic supply may be too high, too low, or not operating.</p> <p>The solenoid may not be actuating properly.</p>	<p>Inspect the pneumatic supply. As necessary, regulate the pneumatic supply to ensure air is supplied at the appropriate pressure.</p> <p>Refer to the <i>Installation, Operation, and Maintenance (IOM) Manual</i> for the solenoid. The solenoid may need to be replaced.</p>
The BIP is not injecting the correct amount of odorant.	The BIP is not set to the desired injection volume.	Adjust the injection volume. See <i>Section 2.3, Start-Up Procedures</i> , for instructions on adjusting the injection volume.

APPENDIX A: REFERENCED OR ATTACHED DOCUMENTS

Welker *Installation, Operation, and Maintenance (IOM) Manuals* suggested for use with this unit:

- IOM-010: Welker OdorEyes BIP-1, BIP-2, BIP-3, and BIP-4 Bellows Injection Pumps
- IOM-033: Welker RV-1, RV-2, RV-2CP, and RV-3 Relief Valves
- IOM-094: Welker SG-4 Sight Glass
- IOM-105: Welker NV-1 and NV-2 Instrument Valves
- IOM-212: Welker F-19 Filter Dryer
- IOM-213: Welker F-9 and F-10 Filters

Other *Installation, Operation, and Maintenance (IOM) Manuals* suggested for use with this unit:

- ASCO Valve, Inc. 1.4 W Low Power Solenoid Valves Low Power Series (Welker IOM-V266)
- Ellis/Kuhnke Controls PM Counters Panel or Base Mounted Pneumatic Counters (Welker IOM-V379)
- Emerson Process Management Regulator Technologies, Inc. Fisher™ 67C Series Instrument Supply Regulators (Welker IOM-V048)
- Emerson Process Management Regulator Technologies, Inc. Fisher™ 1301 Series High-Pressure Regulators Types 1301F and 1301G (Welker IOM-V107)
- Horner APG, LLC XL4 OCS Modules (Welker IOM-V369)
- Max Machinery, Inc. Positive Displacement Flowmeters Models P001, P002, 213, 214, and 215 (Welker IOM-V106)
- MK Battery 8GUI-DEKA Valve-Regulated, Gelled-Electrolyte Battery (Welker IOM-V382)
- Morgan Products Inc. Model TR2 Air Actuated Timer (Welker IOM-V219)
- Morningstar Corporation SunSaver™ Solar Controller (Welker IOM-V346)
- Parker Hannifin Corporation Fluoropolymer Hose (Welker IOM-V174)
- Pentair plc Hoffman Hinge-Cover With 3-Point Latch or Quick-Release Latches, Type 4X Fiberglass Enclosures (Welker IOM-V381)
- Pentair plc Hoffman ULTRX, Type 4X Fiberglass Enclosures (Welker IOM-V380)
- Power-Sonic Corporation PS-1270 12 Volt 7.0 AH Rechargeable Sealed Lead Acid Battery (Welker IOM-V223)
- Swagelok Company Check Valves C, CA, CH, CP, and CPA Series (Welker IOM-V076)
- Swagelok Company Filters FW, F, and TF Series (Welker IOM-V092)
- Swagelok Company One-Piece Instrumentation Ball Valves 40G Series and 40 Series (Welker IOM-V085)
- Swagelok Company Plug Valves P4T and P6T Series (Welker IOM-V102)
- Swagelok Company Quick-Connects QC, QF, QM, and QTM Series (Welker IOM-V088)
- WIKA Instrument Corporation Bourdon Tube Pressure Gauges Type 232.53 and Type 233.53 (Welker IOM-V171)

Welker drawings and schematics suggested for use with this unit:

- System Drawing: OE143SYS.1 (Standard POC)
- System Drawing: OE143SYS.3 (POC With Optional Controller and Solar Panel)
- System Drawing: OE143SYS.5 (POC With Welker F-9 Filter)

APPENDIX B: MAINTENANCE SCHEDULE



Welker recommends keeping high-wear parts on hand and replacing these parts immediately when worn or damaged.



Refer to the *Installation, Operation, and Maintenance (IOM) Manual* for each component for maintenance instructions.

Table B1: POC Maintenance Schedule

Action	Weekly	Every 12 Months	As Necessary
Open F-19 drain valve Q to allow moisture to drain from the filter.	X		
Verify the pneumatic supply pressure and blanket pressure, if applicable.		X	
Rebuild the BIP using a Welker repair kit. <ul style="list-style-type: none"> • Replace the seals and bearing. • Replace the check cartridges. • Inspect the bellows, actuator piston, actuator spring, and actuator housing for damage or wear. 		X	
Rebuild the F-19 using a Welker repair kit. <ul style="list-style-type: none"> • Replace the O-rings and filter cartridge. 		X	
Rebuild the F-9 using a Welker repair kit. <ul style="list-style-type: none"> • Replace the O-rings. • Clean the filter element. • Clean the spring. 		X	
View the controller's current alarms.			X
Inspect the injection pump, tubing, valves, and fittings on the system for leaks.			X
Rebuild the RV-1s using a Welker repair kit. <ul style="list-style-type: none"> • Replace the O-rings. • Inspect the spring and ball for damage or wear. 			X
Replace the controller battery.			X
Maintain the flow meter.			X
Maintain the regulators.			X
Maintain the solenoid.			X
Maintain the pneumatic timer.			X

